

LM2925 Low Dropout Regulator with Delayed Reset

General Description

The LM2925 features a low dropout, high current regulator. Also included on-chip is a reset function with an externally set delay time. Upon power up, or after the detection of any error in the regulated output, the reset pin remains in the active low state for the duration of the delay. Types of errors detected include any that cause the output to become unregulated: low input voltage, thermal shutdown, short circuit, input transients, etc. No external pull-up resistor is necessary. The current charging the delay capacitor is very low, allowing long delay times.

Designed primarily for automotive applications, the LM2925 and all regulated circuitry are protected from reverse battery installations or two-battery jumps. During line transients, such as a load dump (60V) when the input voltage to the regulator can momentarily exceed the specified maximum operating voltage, the 0.75A regulator will automatically shut down to protect both internal circuits and the load. The

LM2925 cannot be harmed by temporary mirror-image insertion. Familiar regulator features such as short circuit and thermal overload protection are also provided.

Features

- 5V, 750 mA output
- Externally set delay for reset
- Input-output differential less than 0.6V at 0.5A
- Reverse battery protection
- 60V load dump protection
- -50V reverse transient protection
- Short circuit protection
- Internal thermal overload protection
- Available in plastic TO-220
- Long delay times available
- P+ Product Enhancement tested

Typical Application Circuit

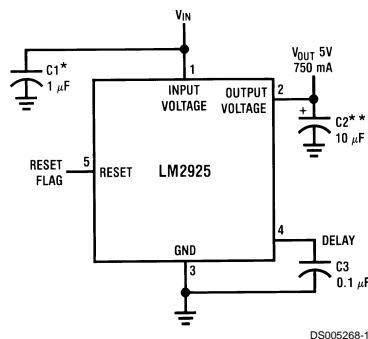

DS005268-1

*Required if regulator is located far from power supply filter.
 ** C_{OUT} must be at least 10 μF to maintain stability. May be increased without bound to maintain regulation during transients. Locate as close as possible to the regulator. This capacitor must be rated over the same operating temperature range as the regulator. The equivalent series resistance (ESR) of this capacitor is critical; see curve.

FIGURE 1. Test and Application Circuit

Connection Diagram

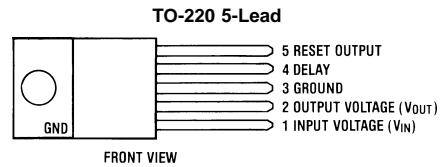

DS005268-2

Order Number LM2925T
 See NS Package Number T05A

Absolute Maximum Ratings (Note 1)

If Military/Aerospace specified devices are required, please contact the National Semiconductor Sales Office/Distributors for availability and specifications.

Input Voltage	
Operating Range	26V
Overshoot Protection	60V

Internal Power Dissipation (Note 2)

Operating Temperature Range	Internally Limited -40°C to + 125°C
Maximum Junction Temperature	150°C
Storage Temperature Range	-65°C to + 150°C
Lead Temperature (Soldering, 10 seconds)	260°C
ESD rating is to be determined	

V_{OUT}
Electrical Characteristics

V_{IN} = 14V, C₂ = 10 μf, I_O = 500 mA, T_J = 25°C (Note 4) (unless otherwise specified)

Parameter	Conditions	Min	Typ	Max	Units
		(Note 3)			
Output Voltage	6V ≤ V _{IN} ≤ 26V, I _O ≤ 500 mA, -40°C ≤ T _J ≤ +125°C	4.75	5.00	5.25	V
Line Regulation	9V ≤ V _{IN} ≤ 16V, I _O = 5 mA 6V ≤ V _{IN} ≤ 26V, I _O = 5 mA		4 10	25 50	mV mV
Load Regulation	5 mA ≤ I _O ≤ 500 mA		10	50	mV
Output Impedance	500 mA _{DC} and 10 mA _{RMS} , 100 Hz-10 kHz		200		mΩ
Quiescent Current	I _O ≤ 10 mA I _O = 500 mA I _O = 750 mA		3 40 90	100	mA mA mA
Output Noise Voltage	10 Hz-100 kHz		100		μV _{rms}
Long Term Stability			20		mV/1000 hr
Ripple Rejection	f _o = 120 Hz		66		dB
Dropout Voltage	I _O = 500 mA I _O = 750 mA		0.45 0.82	0.6	V V
Current Limit		0.75	1.2		A
Maximum Operational Input Voltage		26	31		V
Maximum Line Transient	V _O ≤ 5.5V	60	70		V
Reverse Polarity Input Voltage, DC	V _O ≥ -0.6V, 10Ω Load	-15	-30		V
Reverse Polarity Input Voltage, Transient	1% Duty Cycle, τ ≤ 100 ms, 10Ω Load	-50	-80		V

Reset Output
Electrical Characteristics

V_{IN} = 14V, C₃ = 0.1 μF, T_A = 25°C (Note 4) (unless otherwise specified)

Parameter	Conditions	Min	Typ	Max	Units
		(Note 3)			
Reset Voltage					
Output Low	I _{SINK} = 1.6 mA, V _{IN} = 35V		0.3	0.6	V
Output High	I _{SOURCE} = 0	4.5	5.0	5.5	V
Reset Internal Pull-up Resistor			30		kΩ
Reset Output Current Limit	V _{RESET} = 1.2 V		5		mA
V _{OUT} Threshold			4.5		V
Delay Time	C ₃ = .005 μF		12		ms
	C ₃ = 0.1 μF	150	250	300	ms
	C ₃ = 4.7 μF tantalum		12		s

Reset Output Electrical Characteristics (Continued)

$V_{IN} = 14V$, $C3 = 0.1 \mu F$, $T_A = 25^\circ C$ (Note 4) (unless otherwise specified)

Parameter	Conditions	Min	Typ	Max	Units
		(Note 3)			
Delay Current	Pin 4	1.2	1.95	2.5	μA

Note 1: Absolute Maximum Ratings indicate limits beyond which damage to the device may occur. Electrical specifications do not apply when operating the device beyond its rated operating Conditions.

Note 2: Thermal resistance without a heat sink for junction to case temperature is $3^\circ C/W$ (TO-220). Thermal resistance for TO-220 case to ambient temperature is $50^\circ C/W$.

Note 3: These parameters are guaranteed and 100% production tested.

Note 4: To ensure constant junction temperature, low duty cycle pulse testing is used.

Typical Circuit Waveforms

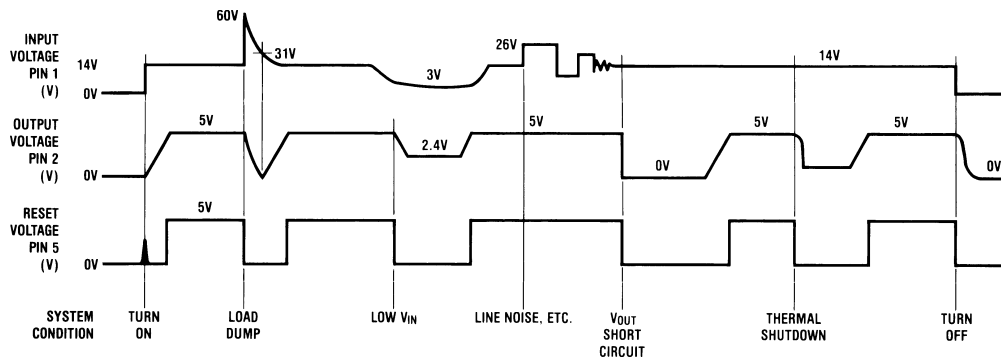

DS005268-3

FIGURE 2.

Typical Performance Characteristics

Reset Voltage

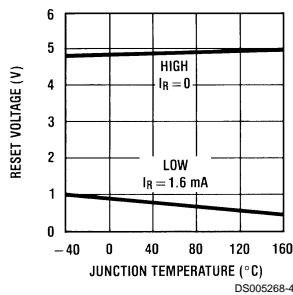

Reset Voltage

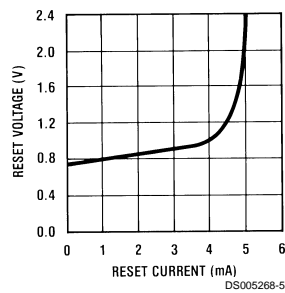

Delay Time

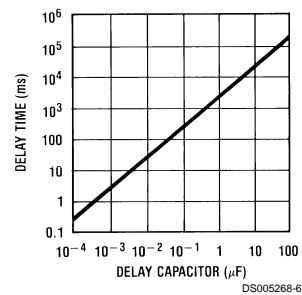

Typical Performance Characteristics (Continued)

Reset Voltage on Power-up

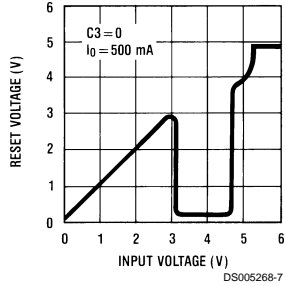

Delay Time

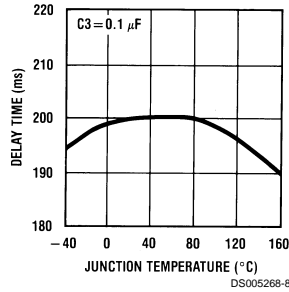

Reset Pull-up Resistor R10

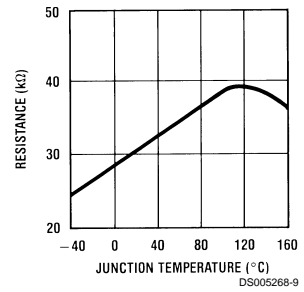

Dropout Voltage

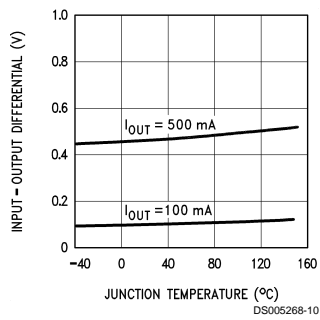

Line Transient Response

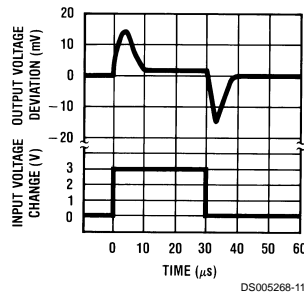

Ripple Rejection

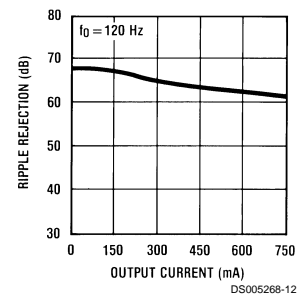

Ripple Rejection

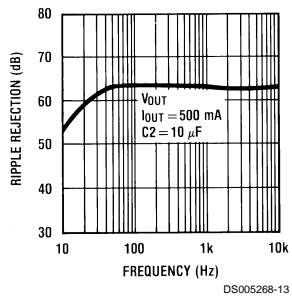

Quiescent Current

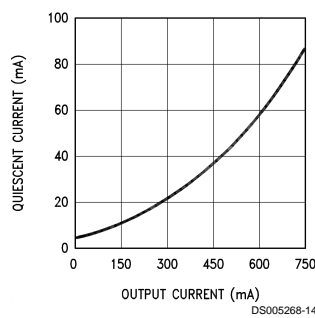

Output Voltage

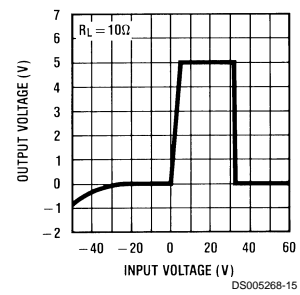

Typical Performance Characteristics (Continued)

Quiescent Current

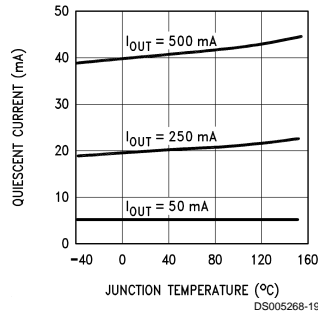

Quiescent Current

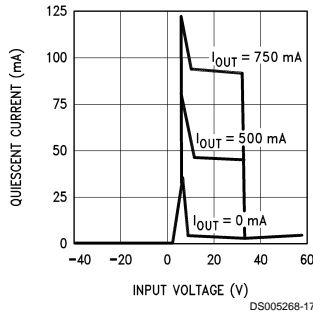

Load Transient Response

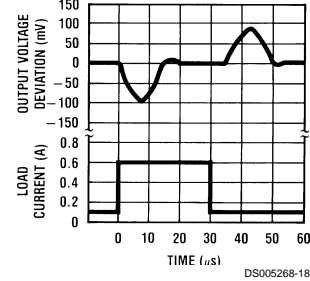

Peak Output Current

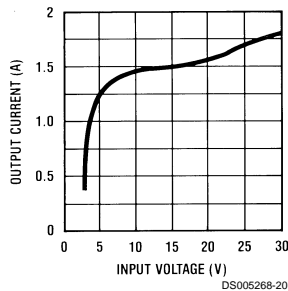

Maximum Power Dissipation (TO-220)

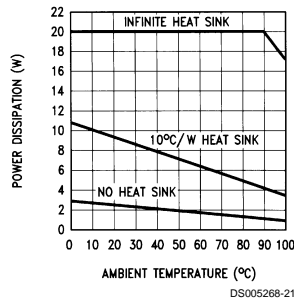

Output Capacitor ESR

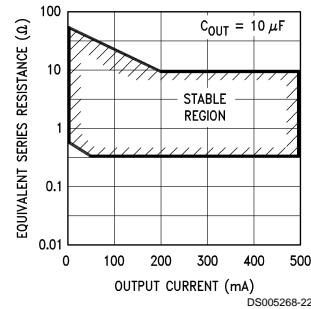

Definition of Terms

Dropout Voltage: The input-output voltage differential at which the circuit ceases to regulate against further reduction in input voltage. Measured when the output voltage has dropped 100 mV from the nominal value obtained at 14V input, dropout voltage is dependent upon load current and junction temperature.

Input Voltage: The DC voltage applied to the input terminals with respect to ground.

Input-Output Differential: The voltage difference between the unregulated input voltage and the regulated output voltage for which the regulator will operate.

Line Regulation: The change in output voltage for a change in the input voltage. The measurement is made under conditions of low dissipation or by using pulse techniques such that the average chip temperature is not significantly affected.

Load Regulation: The change in output voltage for a change in load current at constant chip temperature.

Long Term Stability: Output voltage stability under accelerated life-test conditions after 1000 hours with maximum rated voltage and junction temperature.

Output Noise Voltage: The rms AC voltage at the output, with constant load and no input ripple, measured over a specified frequency range.

Quiescent Current: The part of the positive input current that does not contribute to the positive load current. The regulator ground lead current.

Ripple Rejection: The ratio of the peak-to-peak input ripple voltage to the peak-to-peak output ripple voltage.

Temperature Stability of V_O : The percentage change in output voltage for a thermal variation from room temperature to either temperature extreme.

Application Hints

EXTERNAL CAPACITORS

The LM2925 output capacitor is required for stability. Without it, the regulator output will oscillate, sometimes by many volts. Though the 10 μ F shown is the minimum recommended value, actual size and type may vary depending upon the application load and temperature range. Capacitor effective series resistance (ESR) also effects the IC stability. Since ESR varies from one brand to the next, some bench work may be required to determine the minimum capacitor value to use in production. Worst-case is usually determined at the minimum junction and ambient temperature and maximum load expected.

Output capacitors can be increased in size to any desired value above the minimum. One possible purpose of this would be to maintain the output voltages during brief conditions of negative input transients that might be characteristic of a particular system.

Application Hints (Continued)

Capacitors must also be rated at all ambient temperatures expected in the system. Many aluminum type electrolytics will freeze at temperatures less than -30°C , reducing their effective capacitance to zero. To maintain regulator stability down to -40°C , capacitors rated at that temperature (such as tantalums) must be used.

RESET OUTPUT

The range of values for the delay capacitor is limited only by stray capacitances on the lower extreme and capacitance leakage on the other. Thus, delay times from microseconds to seconds are possible. The low charging current, typically 2.0 microamps, allows the use of small, inexpensive disc capacitors for the nominal range of 100 to 500 milliseconds. This is the time required in many microprocessor systems for the clock oscillator to stabilize when initially powered up. The RESET output of the regulator will thus prevent erroneous data and/or timing functions to occur during this part of operation. The same delay is incorporated after any other fault condition in the regulator output is corrected.

Circuit Schematic

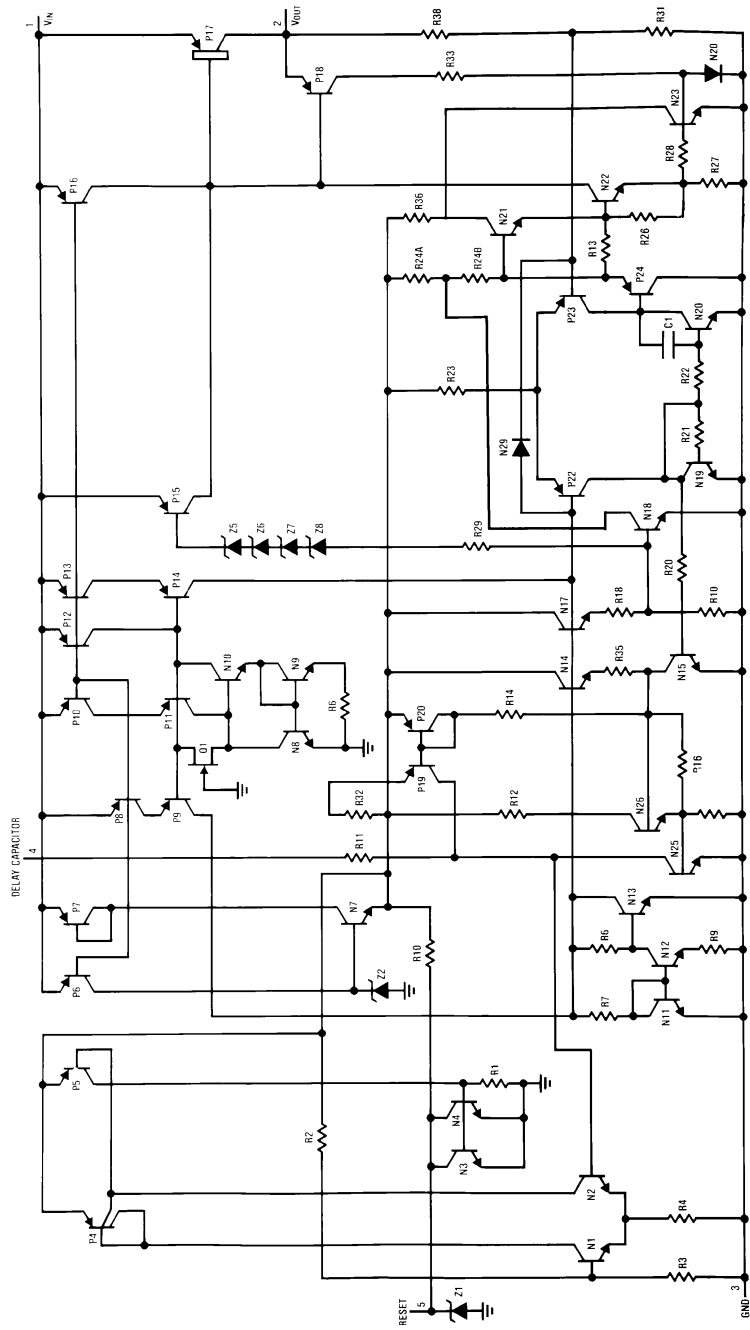
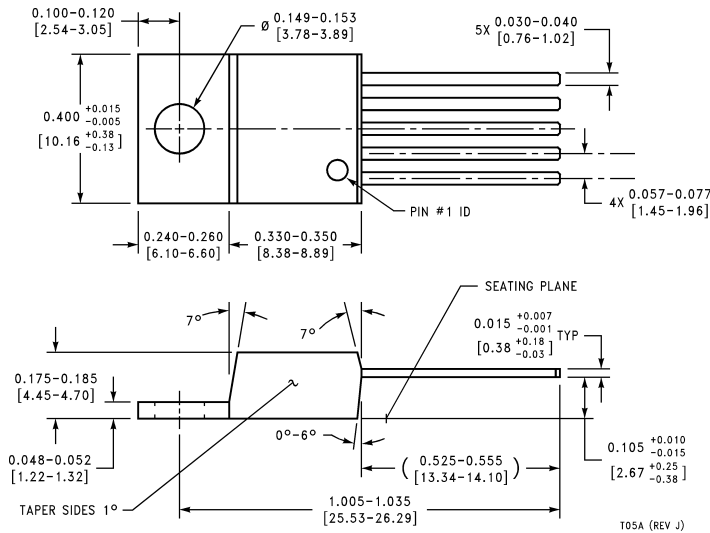

FIGURE 3.

Physical Dimensions inches (millimeters) unless otherwise noted



5-Lead TO-220 Power Package (T)
Order Number LM2925T
NS Package Number T05A

LIFE SUPPORT POLICY

NATIONAL'S PRODUCTS ARE NOT AUTHORIZED FOR USE AS CRITICAL COMPONENTS IN LIFE SUPPORT DEVICES OR SYSTEMS WITHOUT THE EXPRESS WRITTEN APPROVAL OF THE PRESIDENT OF NATIONAL SEMICONDUCTOR CORPORATION. As used herein:

1. Life support devices or systems are devices or systems which, (a) are intended for surgical implant into the body, or (b) support or sustain life, and whose failure to perform when properly used in accordance with instructions for use provided in the labeling, can be reasonably expected to result in a significant injury to the user.
2. A critical component in any component of a life support device or system whose failure to perform can be reasonably expected to cause the failure of the life support device or system, or to affect its safety or effectiveness.



National Semiconductor Corporation
 Americas
 Tel: 1-800-272-9959
 Fax: 1-800-737-7018
 Email: support@nsc.com

National Semiconductor Europe
 Fax: +49 (0) 1 80-530 85 86
 Email: europe.support@nsc.com
 Deutsch Tel: +49 (0) 1 80-530 85 85
 English Tel: +49 (0) 1 80-532 78 32
 Français Tel: +49 (0) 1 80-532 93 58
 Italiano Tel: +49 (0) 1 80-534 16 80

National Semiconductor Asia Pacific Customer Response Group
 Tel: 65-2544466
 Fax: 65-2504466
 Email: sea.support@nsc.com

National Semiconductor Japan Ltd.
 Tel: 81-3-5620-6175
 Fax: 81-3-5620-6179

www.national.com