

APPLICATION NOTE

AN1983

Crystal oscillators and frequency
multipliers using the NE602 and NE5212

1991 Dec

Crystal oscillators and frequency multipliers using the NE602 and NE5212

AN1983

INTRODUCTION

This paper shows how to use the NE602 and NE5212 in VHF and UHF LO generators. The NE602 is a very low power active mixer, yet 7th overtone crystal oscillations are relatively easy to build. Optimization of such circuits is shown in the first part of this paper. Although designed as a fiber optic amplifier, the NE5212 can be used as a feedback oscillator with good results. The second part of this paper shows how the NE602 can be used as a frequency doubler. Combinations of the two techniques can give the RF designer a wide variety of low power VHF/UHF signal sources from overtone oscillators and/or frequency multiplier chains.

OSCILLATORS

One of the most esoteric topics in RF theory is oscillators. Oscillators are fundamental elements in both receiver and transmitter circuitry. Often they are the limiting elements to a receiver's performance. Much work has and is being conducted to build better oscillators and the oscillator's more sophisticated cousin, the synthesizer.

At first glance oscillators would appear to be rather simple. A stage with a gain of more than one is configured with a feedback circuit. Oscillation occurs at the frequency where the feedback gain is greatest. The feedback circuit is usually resonant, configured either from LC or crystal components and providing a narrow frequency band of feedback gain. Difficulty in oscillator design is curious in view of the fact that amplifiers often oscillate undesirably, and it seems it is often more difficult to build a gain stage that does not oscillate than one that does. In fact, oscillators are easy to build. The difficulty lies in building good oscillators. In turn, a "good" oscillator can be defined as meeting the designer's criteria. Predictability and repeatability are two objectives to any engineering design. These features are especially elusive to electronic oscillator design.

Oscillators are found in many, if not most analog and digital electronic devices. Oscillators found in radio receivers are of primary importance to our discussion. The local oscillator or "LO" in a receiver is critical for proper receiver performance. The LO is usually formed from an LC circuit, crystal, or phase locked loop (PLL) synthesizer which usually derives its clock from a crystal.

The use of LC oscillator VFOs "variable frequency oscillator" has been eclipsed to a large extent since the introduction of digital synthesizers. The VFO is still used in inexpensive consumer radios and some high performance radios. The VFO can be less expensive than a synthesizer since it does not require a memory or microprocessor circuit for control. Carefully designed VFOs can also exhibit better phase noise response than PLL synthesizers, a critical consideration for high dynamic range receiver designs. Synthesizers are preferred in higher-end consumer radios and other channelized systems which demand some type of digital frequency control. Digital control allows automatic scanning, frequency hopping, and other functions not practical with an analog VFO.

Crystal oscillator circuits often require demanding tolerances. This is the case when they are used for second IF conversion as in the NE602 circuits. Another case is where an oscillator with very low phase noise is desired for high performance systems. The NE602 uses a Colpitts type oscillator configuration. An excellent feedback type oscillator can be built using the NE5212. These two oscillator types will be presented here in detail.

PROPERTIES OF CRYSTALS

Crystal resonators operate on a mechanical vibration principle called the "piezoelectric" effect. This is in contrast to the LC circuit configuration. Quartz crystals can exhibit circuit Qs up to 1000 times higher

than their LC counterparts. Figure 1 shows the equivalent circuit of a quartz crystal.

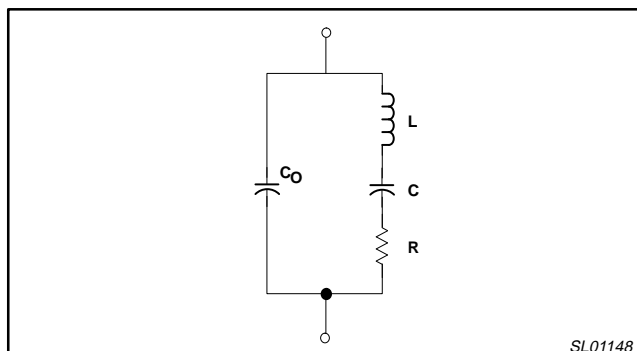

Figure 1. Equivalent Circuit of a Crystal

The exact equivalent circuit constants in Figure 1 will be affected by several mechanical considerations, of which physical size of the crystal is perhaps the most important. The larger the crystal, the lower the resonant frequency. The "cut" of the crystal will effect temperature, frequency range, and other parameters. Figure 2 shows the relationship of impedance to frequency in the vicinity of resonance. Several important points can be drawn from this chart. There are two resonant frequencies, a series and a parallel resonance. These are shown by the impedance minimum and maximum respectively.

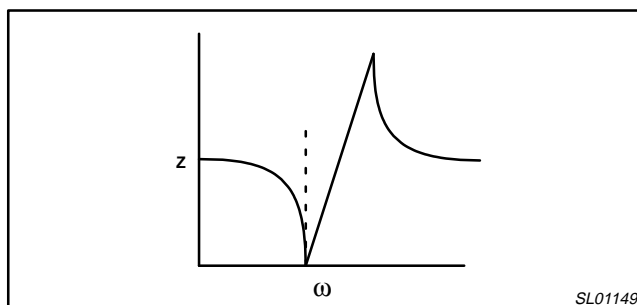

Figure 2.

An important point relating to oscillator design is that large phase shifts can be noticed over relatively small changes in frequency for crystals. This is not surprising when the very high circuit Q is considered. This very large df/dw term allows the crystal to compensate for undesired phase shifts in the feedback circuit without "pulling" the operating frequency significantly. The circuit in Figure 5 shows a simple non-inverting feedback oscillator. The phase shift across a series resonant circuit is zero. However, the phase shift of the transfer function of the amplifier will probably be slightly offset from zero. Therefore, the exact frequency of oscillation will be slightly offset from the exact resonance of the crystal with the crystal "locking in" the exact phase/frequency combination. This phenomena exists for all crystal oscillator configurations.

If the frequency of operation must be more exactly specified than this "pull" a "trimming" capacitor or inductor can be placed in the circuit to change the feedback phase relationship and force the crystal frequency to move slightly. Alternatively very careful design and experiments must be performed to assure consistent performance. Often, if the crystal oscillator is to be operated over a wide temperature range the temperature coefficients become the largest term in frequency tolerance calculations. These coefficients are provided by the crystal manufacturers.

Crystal oscillators and frequency multipliers using the NE602 and NE5212

AN1983

Typical values for a 2MHz crystal relating to Figure 1 might be $L=250\text{mH}$, $C=.04\text{pF}$, $R=125\text{ ohms}$, and $C1=4\text{pF}$. Notice the high $C1/C$ and L/C ratios. Of paramount importance in crystal oscillator

design is the series resistance R . Figure 3 plots a typical relationship between frequency and maximum R . The value of R is critical when designing the loading circuit for the crystal.

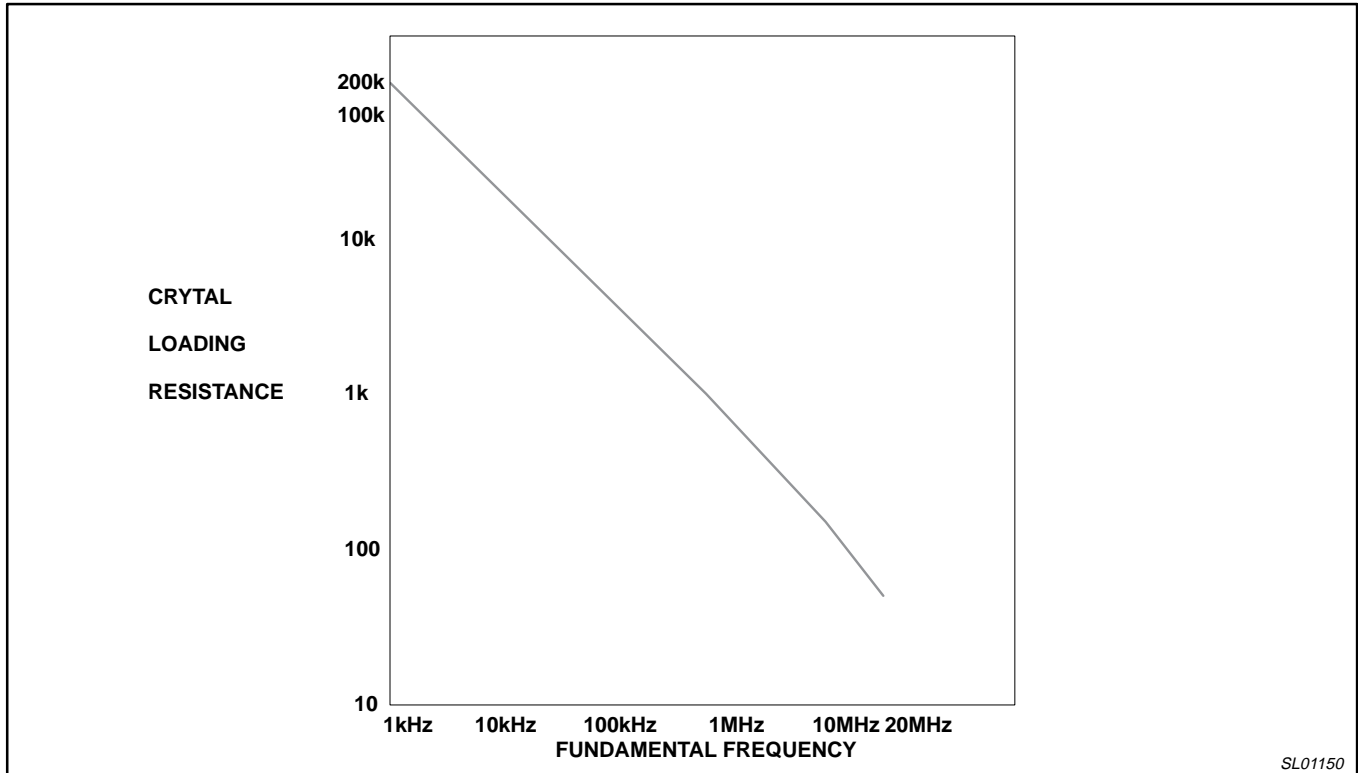

Figure 3.

Crystals are usually specified by their series or parallel resonant frequencies, or both. An oscillator will nearly always operate near its series resonance, the parallel resonance being more of a convenience of measurement. The terms “series” and “parallel” resonant operation are often used but simply refer to a low or high loading impedance across the crystal’s terminals respectively. The “loading” impedance can be measured by removing the crystal and “look into” the circuit at the operating frequency.

The thickness or mass of the crystal will largely determine its resonant frequency. However, the upper maximum resonant frequency is about 20MHz. Above this frequency the crystal is too thin, and can crack easily. Piezoelectric effects allow for “overtone” operation at odd order harmonic terms. Practice allows for operation of overtone crystals up to about 200MHz. Any crystal will “try” to oscillate at its fundamental resonance. If the circuit does not allow a favorable phase response for oscillation at the fundamental frequency, overtone oscillation is possible. An overtone oscillator circuit must be configured to allow proper phase relationships to occur at the desired overtone frequency and improper phase relationships at all lower order frequencies.

Figure 4 shows the equivalent circuit for a crystal, including the overtone elements. The overtone and fundamental frequencies are never exactly harmonically related. Therefore, a crystal to be used in an overtone application must be specified for that exact overtone frequency. The exact frequency of operation will be determined by the cumulative phase response of the entire circuit, in overtone as well as fundamental oscillators. Predicting the phase response of

the passive oscillator components (inductors and capacitors) is relatively easy. Accurate prediction of the active device and crystal performance is extremely difficult. Practical design considerations are possible, particularly if we limit the number of configurations.

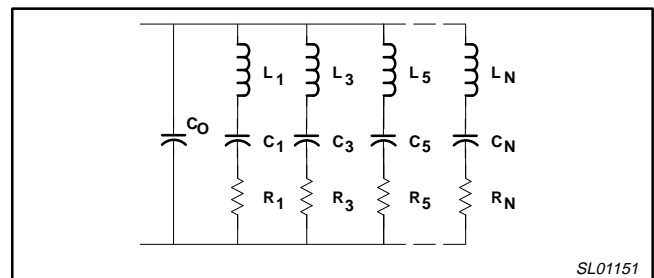

Figure 4. Overtone and Fundamental Equivalent Circuit

DESIGNING CRYSTAL OSCILLATORS

Two oscillator configurations will be treated in this section. Figure 5 shows a model of a feedback oscillator. The amplifier is non-inverting and should have a gain of greater than 1. The crystal will show a zero degree phase shift at series resonance, and consequently the circuit will oscillate very close to this frequency. Figure 6 shows a very simple practical circuit. This circuit is actually an outstanding crystal oscillator. The output into a 50Ω load is 0dBm. The frequency stability is excellent particularly with small variations in supply voltage. The NE5212 has a differential output

Crystal oscillators and frequency multipliers using the NE602 and NE5212

AN1983

thus the inverting output acts as an effective buffer. Consequently load fluctuations have little effect on the oscillator performance.

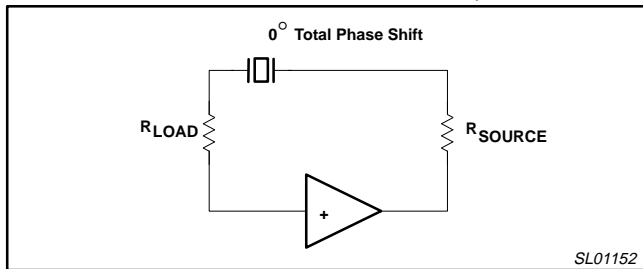

Figure 5.

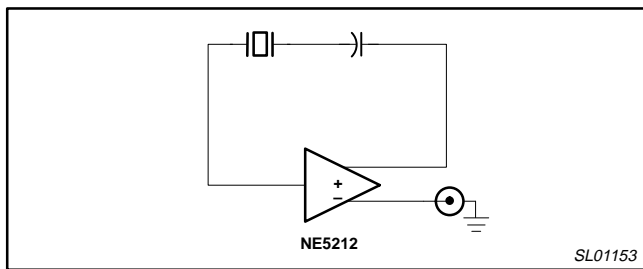

Figure 6. Practical Feedback Oscillator with Output Buffer

Unlike the feedback oscillator, the Colpitts relies upon two 90 degree phase shift circuits to affect oscillation. The crystal shunts the feedback loop rather than being in series with it. Figure 7 shows the ideal Colpitts model while Figure 8 shows a practical Colpitts circuit built around the oscillator portion of the NE602. The amplifier output is taken off the emitter, and its input applied to the base. The Colpitts circuit is ideal for bipolar RF applications. FETs are more effective in the Colpitts configuration at lower frequencies because of the higher input impedances they provide. This is useful at these lower frequencies because the series crystal resistance becomes very high and crystal loading resistances must also be very high. At frequencies above several megahertz the crystal resistance drops and the bipolar's lower output emitter impedance is more effective in driving the lower crystal impedance.

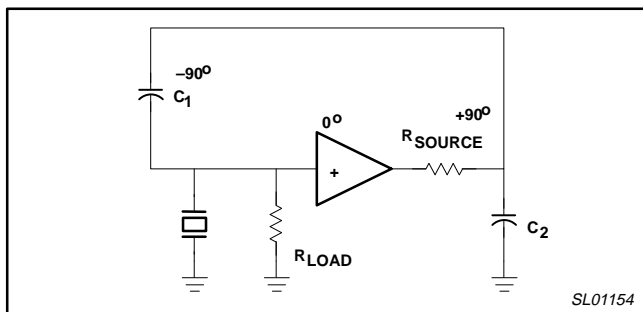

Figure 7. Model of Colpitts Oscillator

The Colpitts oscillator resembles an emitter follower circuit in that the amplifier output is taken off the emitter and the input is its base. Stated another way it is a "common collector" amplifier. Additionally, the transistor exhibits a voltage gain of slightly less than one. However, emitter follower amplifiers are usually used as linear

impedance transformers and/or buffers. The Colpitts oscillator is not very linear. However, for the purpose of understanding its operation, it is valid to think of it as an emitter follower.

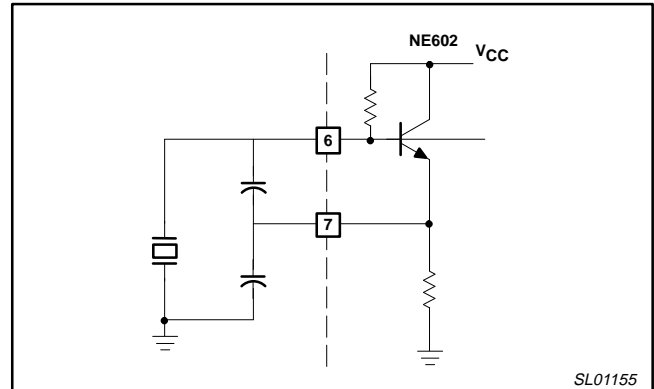

Figure 8.

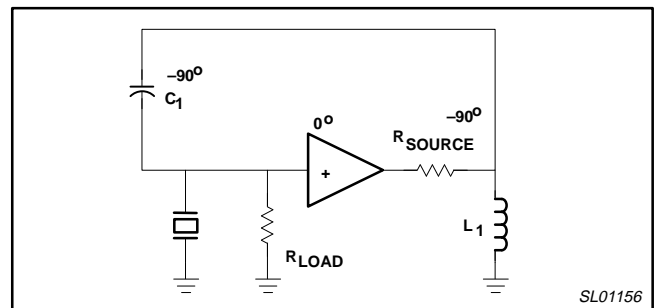

Figure 9.

The simplified model is useful for describing overtone circuits as well. In Figure 9 an inductor L has replaced C2 in Figure 7. The result is a 180 degree phase shift, and the circuit will not oscillate. In figure 10 C2 reappears and a DC blocking capacitor C3 is placed in series with the inductor. For oscillation to occur the LC2 tank must look capacitive at the operating frequency to satisfy the Figure 7 model. The resonant frequency of the tank must be somewhere between the desired overtone and next lower overtone frequencies. This condition will render the tank capacitive at the desired overtone and inductive at lower harmonic frequencies. It will also be capacitive at higher overtones but the crystal at higher overtones is more lossy, forcing the oscillation to occur at the first capacitive overtone. The series resonant frequency formed by LC3 should be lower than the crystal fundamental frequency. This will assure that the LC2, C3 circuit "looks" inductive down to and below the fundamental resonant frequency. Finally C3 should not be so large as to actually "look" inductive at the overtone frequencies. Care must be taken to determine the resonant frequency and consequently the inductance of C3. If the series resonant frequency is about 1/2 that of the fundamental, these conditions will be met in most cases.

The Colpitts crystal oscillator using the NE602 has an upper frequency limit of approximately 100MHz. This limitation and other performance improvements can be realized by using a form of feedback oscillator known as the Butler.

Crystal oscillators and frequency multipliers using the NE602 and NE5212

AN1983

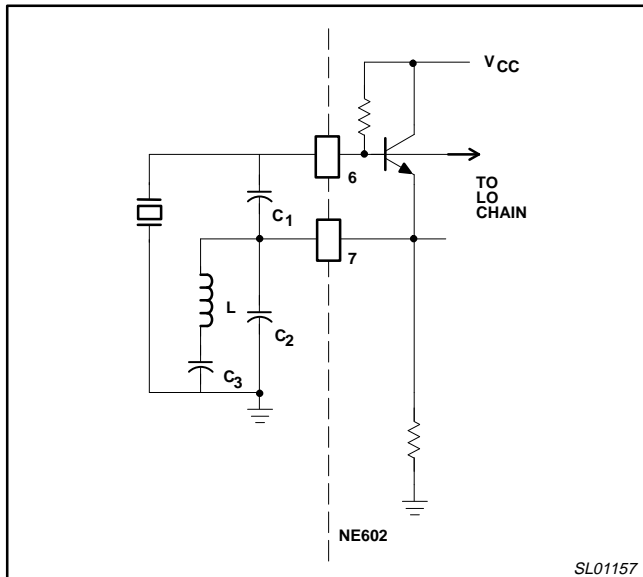

Figure 10. Overtone Oscillator Configuration for NE602

BUTLER CRYSTAL OSCILLATORS FOR THE NE602

The basic feedback oscillator is shown in Figure 5. This circuit can be configured around the NE602 oscillator by using the emitter as the output (Pin 7) and the base as the input (Pin 6). Figure 11 shows a practical Butler 7th overtone crystal oscillator which gives good performance at over 150MHz.

In the Butler “C-tapped” oscillator the crystal is in series with the emitter output. The feedback of the circuit is maximum at or near the series resonance of the crystal. The low impedance shown by the crystal at this frequency allows for greater feedback, and consequently, oscillation. The LC tank of L1, C1, C2, and C3 forms a resonant voltage transformer and provides a net voltage feedback gain. Unlike the Colpitts the Butler LC tank is resonant and consequently voltage feedback is considerably greater at the desired overtone frequency. This is the reason that higher frequency response is possible with the Butler. (Resonant circuits certainly do have advantages in RF work!) The Butler is perhaps the best configuration for overtone oscillators where maximum frequency operation is desired.

Either L or C tapped circuits can be used for the voltage transformation. However, the C-tapped version will force the oscillation at or slightly above the crystal series resonance. L-tapped circuits will oscillate somewhat below series resonance. The Butler oscillator has two other advantages. First the crystal waveforms are near optimum and there is a distinct lack of parasitics.

One problem encountered with the NE602 Butler is its tendency to oscillate at the LC tank resonant frequency rather than the crystal series resonant frequency. This is critical with the NE602 circuit in overtone oscillators. This problem is caused by the shunting capacitor C0 in the crystal (Figure 1). The problem can be resolved by the addition of L2. The resulting L2-C0 parallel resonant circuit creates a high impedance trap at the overtone frequency. The series resonant overtone circuit of the crystal will then become the frequency determining element of the oscillator. At these high frequencies the tuning of L1 is somewhat critical for oscillation to occur. As L1 is tuned off the overtone frequency the circuit resumes its VFO-like characteristics.

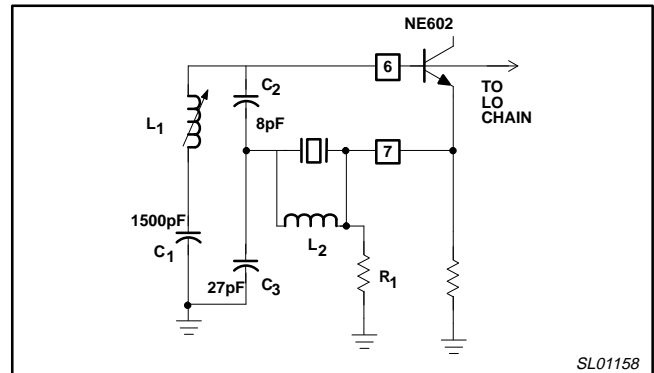

Figure 11. 7th Overtone 154.9MHz Butler Oscillator Using the NE602

Since the NE602 oscillates so readily at VHF, the circuit in Figure 12 is included. Operating frequencies of over 300MHz are easy to construct using the NE602 in a VFO configuration.

Butler circuits have been built and repeated with good results for crystal oscillators up to the 7th overtone using the NE602. 9th overtone circuits have also been constructed but are extremely difficult to stabilize and performance is difficult to duplicate. The 7th overtone configuration may be the practical limit for the NE602, although more work is needed to confirm this estimation. 7th overtone oscillator design is never trivial. Considering the oscillator transistor is starved with a mere 600µA bias current at a 5V supply a 7th order crystal oscillator at 150MHz is quite impressive.

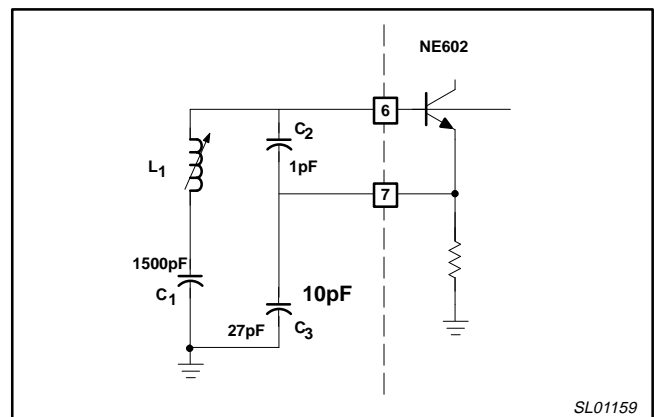

Figure 12. VHF VFO Circuit Produces Reliable Operation to 300MHz

As with the Colpitts, selecting component values for the Butler oscillator is relatively easy, at least for getting the circuit to function. Circuit optimization might require exact values to be “tweaked” for a specific level of performance and power consumption. Here are some general guidelines for the Butler configuration in Figure 11.

1. C1 functions only as a DC block for L1. It should be large enough to have very low reactance at the operating frequency but not so large that its parasitic inductance creates a C1 resonant frequency below about 1GHz. A miniature 1500 pF high Q ceramic was used in all successful tests. C1, C2 and C3 were all miniature ceramics in all tests.
2. C2 should be determined by C3, although a practical minimum value for C2 seems to be 5pF. The ratio of C3/C2 should be between 3 and 4, although ratios of 1/1 were successfully tested. The series combination of C2 and C3 determines the capacitance of the tank. L1 is then chosen to resonate the system at

Crystal oscillators and frequency multipliers using the NE602 and NE5212

AN1983

the operating frequency. Permeability tuned high Q inductors are preferred with unloaded Qs of about 100.

3. C3 should be selected so its impedance is less than that of the crystal's internal resistance. C2 can be tuned to force the circuit to oscillate at the crystal's series resonance.
4. L2 should form a parallel resonant circuit with the crystal shunting capacitance (C0 in Figure 1). It is recommended that this inductor be variable when breadboarding, but could be fixed for production runs. L1 will probably have to be tuned for each production unit.
5. R1 can be used to increase the oscillator bias current. The internal emitter resistor is about 20K. R1 can be as low as 5K. This value is a good starting point for breadboarding the Butler. After the oscillator is running properly, R1 can be reduced or even removed for minimum current consumption and component elimination. One circuit worked well in a 7th overtone mode with R1 removed at 150MHz.
6. Great care must be taken if C2 and/or C3 are variable. The highest Q variable capacitors (lowest capacitor inductance) available are essential. The ideal oscillator breadboard consists of all variable components for convenience but watch out for circuit Q.

FREQUENCY MULTIPLICATION

Crystal overtone oscillators have practical limitations of about 200MHz in traditional discrete circuits and about 150MHz in advanced low power ICs like the NE602. For higher frequencies the crystal oscillator frequency must be "mixed" with another signal to derive a higher frequency.

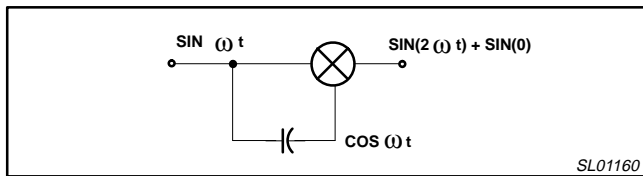

Figure 13. Mathematical Model of a Multiplying Frequency Doubler

A frequency multiplier takes advantage of the harmonic products which result from a non-linear amplifier. The desired harmonic is tuned with an LC tank, rejecting the fundamental and other harmonics. This method is simple, but the harmonic will always be lower in amplitude than the fundamental at the output of the amplifier. The

second harmonic can be 10 to 15dB higher than the fundamental if the signal is multiplied by itself in an NE602. Since the frequency products are the sum and difference of the inputs a multiplier will yield twice the input frequency and the difference, which is a DC component. Figure 13 shows the mathematical model of the frequency multiplier for doubler applications. The DC offset can be reduced to zero by providing a 90 degree phase shift in one of the legs to assure a SIN(0) rather than COS(0) term.

Figure 14 shows a practical NE602 frequency doubler circuit. The oscillator is operating as a fundamental Colpitts. R and C provide attenuation, DC isolation, and the phase shift. The second harmonic of the oscillator will be

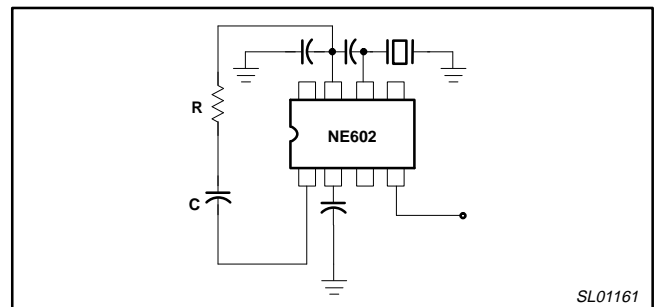

Figure 14. Practical Oscillator/Doubler

about 10dB higher than the fundamental without tuned circuits! Two similar NE602 stages were built to follow the oscillator stage and a x8 multiplier was constructed (Figure 15). Without any tuned circuits the 8th harmonic was about 10dB higher than any other term at the output. The upper frequency limit of the output using this technique is about 500MHz. Of course, tuned circuits will be required to clean up the response at each doubler's output. However, this type of broadband multiplier can relax the necessary selectivity needed to "pick off" the desired harmonic. It is convenient to let the silicon perform the trig crunching rather than tuned LC circuits!

SUGGESTED READING

"Crystal Oscillator Circuits", by Robert J. Matthys, John Wiley & Sons, 1983 is an excellent text that deals with a wide variety of crystal oscillator configurations. This text is highly recommended in conjunction with this application note. However, the essential elements have been condensed to form this paper.

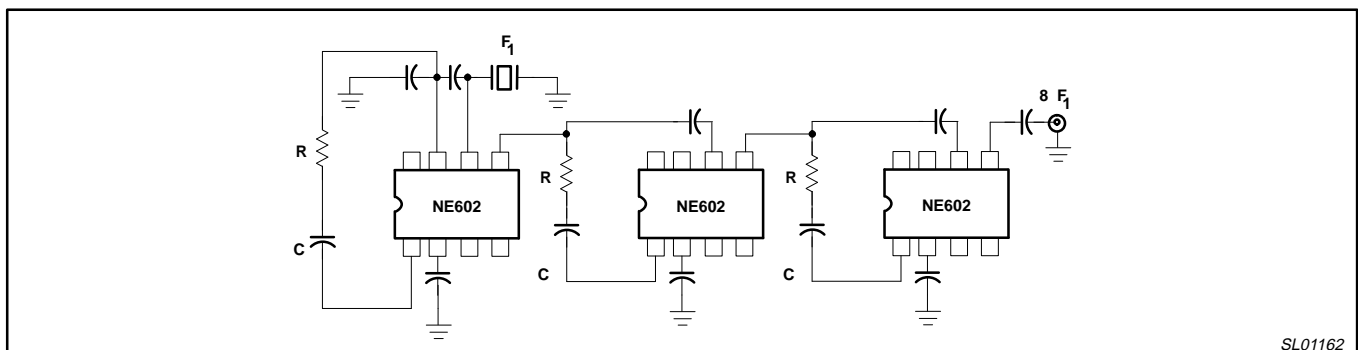

Figure 15. Broadband Oscillator and x8 Frequency Multiplier