

## Selecting the Optimum Voltage Reference

*What could be more basic than a voltage reference - a simple, constant reference voltage? As is all design topics, there are tradeoffs. This article discusses the different types of voltage references, their key specifications, and the design tradeoffs, including accuracy, temperature-independence, current drive capability, power dissipation, stability, noise, and cost.*

You can find voltage references inside almost any advanced electronic product, either standalone or integrated into larger functions. For example:

- In a data converter, a reference provides an absolute voltage to compare to the input voltage to determine the proper digital code.
- In a voltage regulator, a reference provides a known value which is compared to the output to develop the feedback that is used to regulate the output voltage.
- In a voltage detector circuit, the reference is used as an absolute threshold to set the trip point.

The required specifications depend on the application. This article discusses the different types of voltage references, their key specifications, and design tradeoffs. It offers information to help designers select the optimum voltage reference for their applications.

### The Ideal

An ideal voltage reference would have a perfect initial accuracy and maintain its voltage independent of changes in load current, temperature, and time. In the real world, a designer must make tradeoffs such as: Initial Voltage Accuracy, Voltage Temperature Drift and Hysteresis, Current Source and Sink capability, Quiescent Current (or Power Dissipation), Long Term Stability, Noise, and Cost.

### Types of Reference

The two most common types of references are Zener and Bandgap. Zeners are usually used in two-terminal shunt topologies. Bandgap references are usually used in three-terminal Series topologies.

### Zener Diodes and Shunt Topologies

Zener diodes are diodes optimized for operation in the reverse-bias breakdown region. Because breakdown is relatively constant, it can be used to generate a stable reference by driving a known current in the reverse direction.

One big advantage of zeners is the wide range of voltages that are available, from 2V up to 200V. They also have a wide range of power handling capability, from several milliwatts to several watts.

The key disadvantages of zener diodes is that they are not precise enough for high-precision applications and their power consumption makes them a tough fit for low-power applications. An example is the BZX84C2V7LT1, which has a breakdown, or nominal reference voltage, of 2.5V with a variation from 2.3V to 2.7V, or +/-8% accuracy. This is suitable only for applications that need little precision.

An additional concern with a zener reference is the output impedance. Our example above has an internal impedance of  $100\Omega$  at 5mA and  $600\Omega$  at 1mA. A non-zero impedance will cause an additional variation in the reference voltage depending on the variation in load current. Selecting a zener with low output impedance minimizes this effect.

Buried zener diodes are a specific type of zener that are more stable than a regular zener, due to their structure which places them below the surface of the silicon.

An alternative to an actual zener diode is an active circuit that emulates a zener. Circuitry allows the device to significantly improve upon the classic limitations of the zener. One such device is the MAX6330. It has a tight 1.5% (max) initial accuracy over a 100uA to 50mA variation in load. A typical implementation of this type of IC is shown in Figure 1.

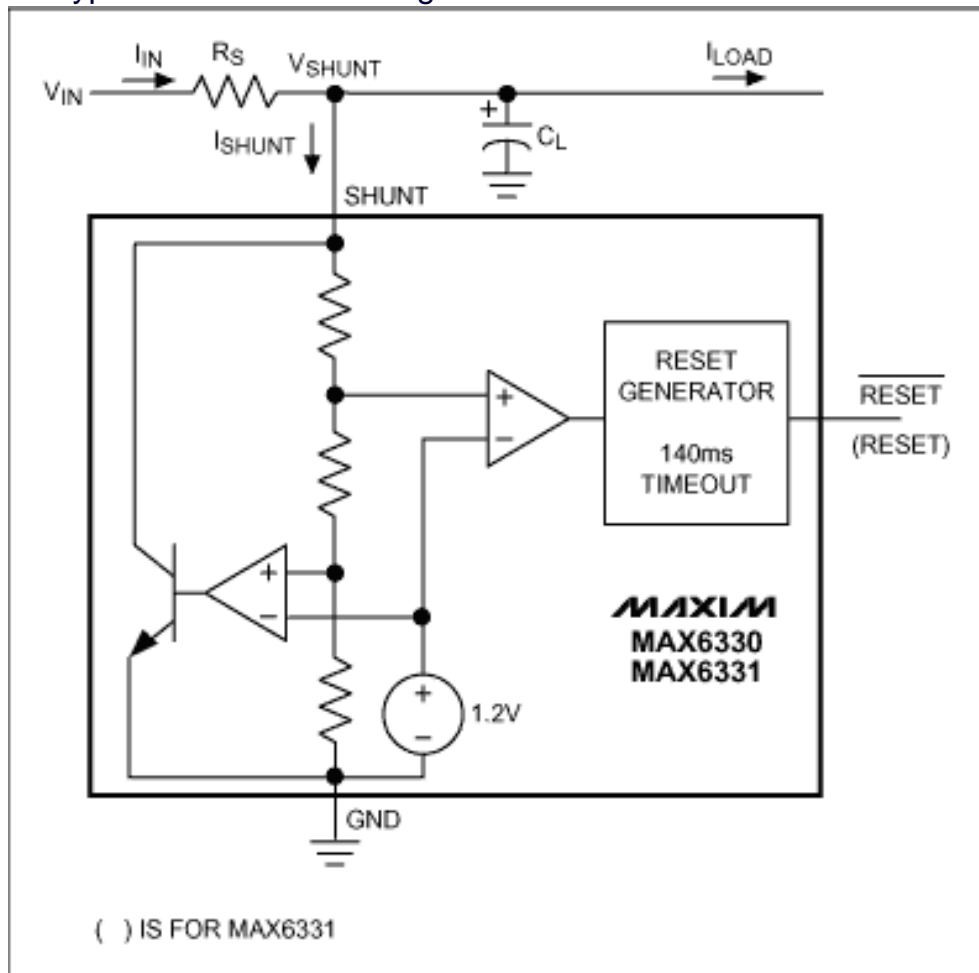

Figure 1.

## Selecting the Proper Shunt Resistor

All shunt configuration references need a current limiting resistor in series with the reference element. It can be calculated from the following equation:

$$R_S = (V_{IN(max)} - V_{SHUNT(min)}) / (I_{SHUNT(max)} + I_{LOAD(min)}) \leq R_S \leq (V_{IN(min)} - V_{SHUNT(max)}) / (I_{SHUNT(min)} + I_{LOAD(max)})$$

Where:

$V_{IN}$  is the input voltage range

$V_{SHUNT}$  is the regulated voltage

$I_{LOAD}$  is the output current range

$I_{SHUNT}$  is the minimum shunt operating current

Note that a shunt circuit will *always* consume  $I_{LOAD(max)} + I_{SHUNT}$  whether or not a load is present.

The same shunt can be used for 10Vin or 100Vin by properly sizing  $R_S$ . Choosing the largest nominal resistor value for  $R_S$  gives the lowest current consumption. Remember to provide a safety margin to incorporate the worst-case tolerance of the resistor used. You should also ensure that the resistor's power rating is adequate, using either of the following two general power equations:

$$\begin{aligned} P_R &= I_{IN}(V_{IN(max)} - V_{SHUNT}) \\ &= I_{IN}^2 R_S \\ &= (V_{IN(max)} - V_{SHUNT})^2 / R_S \end{aligned}$$

## Bandgap References and Series Mode Topologies

The key differences between a shunt and series reference is that the three terminal series-mode voltage references do not require an external resistor and have significantly lower quiescent power. The most common form is the ubiquitous bandgap reference.

### Bandgap Basics

A bandgap reference develops two voltages: One has a positive temperature coefficient (tempco) and one has a negative tempco. Together, they have a zero-tempco sum at the output.

The positive tempco is usually derived from the difference of two  $V_{be}$ 's running at different current levels. The negative tempco uses the naturally negative tempco of the  $V_{be}$  voltage (see Figure 2).

In practice, the tempco sum is not exactly zero. Depending on design details like the IC circuit design, packaging, and manufacturing test capabilities, these devices can usually achieve a  $V_{out}$  tempcos between 5 and 100ppm per degree C.

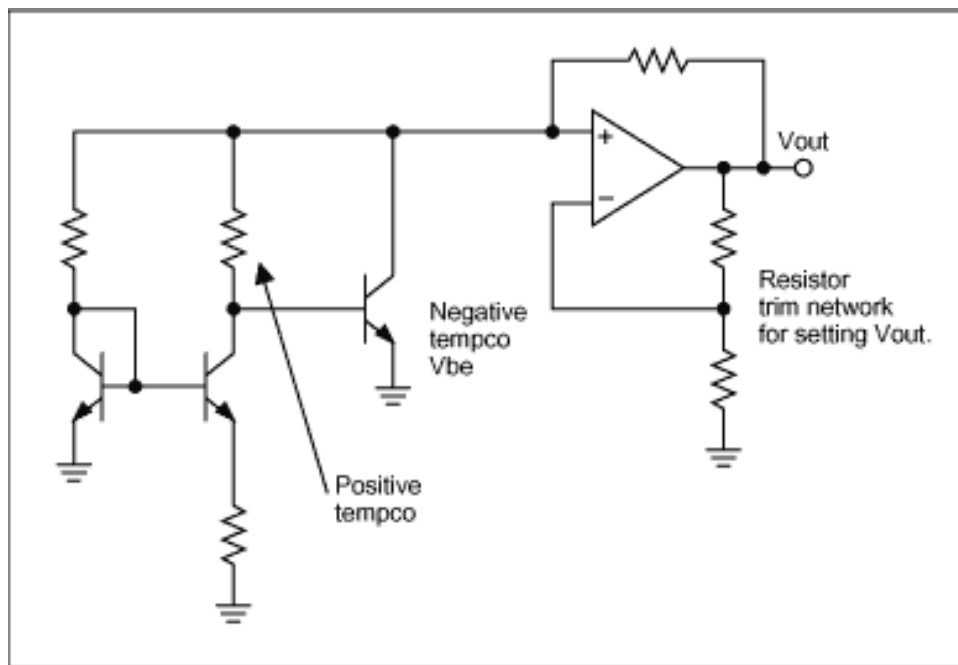

Figure 2. Bandgap Voltage Reference.

The use of either a shunt or series topology is typically dictated by the application and the desired performance. Please refer to Table 2 for some comparisons between zeners in shunt topologies and bandgaps in series topologies.

Table 1. Voltage Reference Comparison Guide

What	Zener - Shunt Topology	Buried Zener - Shunt Topology	Band-Gap - Series Topology
Pro's	<ul style="list-style-type: none"> <li>Wide/high <math>V_{in}</math> capable</li> <li>Best for non-power critical applications due to higher Iquiescent (1-10mA)</li> <li>&gt;1% FS initial Accy.</li> </ul>	<ul style="list-style-type: none"> <li>Wide/high <math>V_{in}</math> capable</li> <li>Best for non-power critical applications due to higher Iquiescent (1-10mA)</li> <li>0.01% to 0.1% FS Initial Accy</li> </ul>	<ul style="list-style-type: none"> <li>Typically lower <math>V_{in}</math> range</li> <li>Low Quiescent current(<math>\mu</math>A to ~1mA)</li> <li>No ext resistor</li> <li>Lower Iquiescent</li> <li>0.05% to 1% FS initial Accy</li> <li>Low dropout voltages</li> </ul>
Con's	<ul style="list-style-type: none"> <li>Current is always used</li> <li>Requires external resistor</li> <li>Lower precision</li> <li>Can only sink current</li> <li>High dropout voltage</li> </ul>	<ul style="list-style-type: none"> <li>Higher Iquiescent than bandgaps</li> </ul>	<ul style="list-style-type: none"> <li>Limited <math>V_{in}</math> range</li> <li>Pass element losses</li> </ul>
Gotcha's	<ul style="list-style-type: none"> <li>Long-Term stability</li> </ul>	<ul style="list-style-type: none"> <li>Not all Series devices sink current</li> </ul>	<ul style="list-style-type: none"> <li>Not all Series devices sink current</li> </ul>

## System Design Issues and Reference Selection

### Power Consumption

If you are designing a medium precision system like a high-efficiency, +/-5% power supply or perhaps an

8-bit data acquisition system that requires minimal power, you could use a device like the MAX6025 or MAX6192. Both are 2.5V references that consume a maximum of 35uA. They have very low output impedance so the reference voltage will be virtually independent of  $I_{OUT}$ .

### **Source and Sink Current**

Another specification is the reference's ability to source and sink current.

Most applications require a voltage reference to source current to the load(s) and of course, the reference needs to be able to supply the required load current. It also needs to supply any  $I_{bias}$  or leakage currents -- their sum can sometimes exceed the load currents.

ADCs and DACs typically require between tens of micro-amps for a converter like the MAX1110, to 10mA(max) for devices like the AD7886. The MAX6101-5 family of references sources 5mA and sinks 2mA. For really heavy loads, the MAX6225/41/50 family will source and sink 15mA.

### **Temperature Drift**

Temperature drift is normally a correctable parameter. It is typically a very repeatable error. Correction can be accomplished by adding a calibration step or by reading a value from a look up function that has been previously characterized.

Calibration is very common in high-resolution systems. In a 16-bit system - you will need better than a 1ppm/C reference for the commercial (0C to 70C) temperature range to stay within the +/-1LSB over the entire range, with a 25C reference point.  $\Delta V = (1\text{ppm/C} * 5\text{V} * 45\text{C}) = 255\text{uV}$ . This same temperature drift extended over the industrial temperature range would only be acceptable for a 14-bit system.

### **Noise**

Noise usually consists of random thermal noise, but can also include flicker noise and other spurious sources. The MAX6150, MAX6250 and MAX6350 are all good choices for low noise applications with 35uV, 3uV and 3uVp-p noise performance respectively. All of these will contribute less than 1LSB of noise into your measurement. One could over-sample and average, but it comes at the cost of processor power and increased system complexity and cost.

### **Output Voltage Temperature Hysteresis**

This parameter is defined as the change in output voltage at the reference temperature (25C) due to sequential but opposite temperature excursions (i.e.: hot-to-cold and then cold-to-hot). Very negative effects can occur due to this effect since its amplitude is directly proportional to the temperature excursion the system underwent. In many systems this type of error is not very repeatable. This parameter is a function of design of the IC circuit as well as effects from the packaging. For example: The MAX6001 type device in a 3-pin SOT23 has a typical Temperature Hysteresis of 130ppm. But a larger, more stable package, like the MAX6190 in the SO-8, has only 75ppm.

### **Long Term Stability**

This parameter is defined as a change in voltage over time. It is primarily due to die stress or perhaps ion migration that exists in a package or family of devices. It is important to note that the circuit board cleanliness can show up as a long-term change over time; especially over temperature and humidity. This effect, at times can be larger than the inherent device stability. Long-term stability is typically only specified at the reference temperature, usually 25C.

## **Summary**

The difficulties of designing any system lie in balancing the trade-offs: Cost, size, precision, power consumption, etc. It is important to consider all of the pertinent parameters when selecting the optimum reference for a design. It is interesting to note that many times a more expensive component can result in a lower total system cost due to the reduction in cost of compensation/calibration in manufacturing phase.

**Table 2. Abbreviated list of MAXIM Voltage References**

Part Number	Output Voltage (V)	Supply Voltage Range (V)	Temp. Drift (ppm/° C max)	Initial Accuracy TA=+25° C (% F.S. max)	Quiescent Current (mA max)	0.1Hz to 10Hz Noise(µVp-p), max (typ)	Package Options	Temp. Ranges*
MAX6160	Adj.(1.23 to 12.4)	2.7 to 12.6	100	1	100µA	(15)	SOT143, SO	E
MAX6120	1.2	2.4 to 11	100	1	70µA	(10)	SOT23, SO	E
MAX6520	1.2	2.4 to 12.6	50	1	70µA	(10)	SOT23, SO	E
MAX6001	1.25	2.5 to 12.6	100	1	45µA	25	SOT23	E
MAX6012	1.25	2.5 to 12.6	20 to 30	0.3 to 0.5	35µA	25	SOT23	E
MAX6190	1.25	2.5 to 12.6	5 to 25	0.16 to 0.48	35µA	25	SO	E
MAX6021	2.048	2.5 to 12.6	20 to 30	0.2 to 0.4	35µA	40	SOT23	E
MAX6191	2.048	2.5 to 12.6	5 to 25	0.1 to 0.5	35µA	40	SO	E
MAX872	2.5	2.7 to 20	40	0.2	10µA	(60)	DIP, SO	C, E
MAX873	2.5	4.5 to 18	7 to 20	0.06 to 0.1	28µA	(16)	DIP, SO	C, E
MAX6002	2.5	2.7 to 12.6	100	1	45µA	60	SOT23	E
MAX6025	2.5	2.7 to 12.6	20 to 30	0.2 to 0.4	35µA	60	SOT23	E
MAX6125	2.5	2.7 to 12.6	50	1	100µA	(15)	SOT23, SO	E
MAX6192	2.5	2.7 to 12.6	5 to 25	0.1 to 0.4	35µA	60	SO	E
MAX6225	2.5	8 to 36	2 to 5	0.04 to 0.1	2.7	(1.5)	DIP, SO	C, E
MAX6325	2.5	8 to 36	1 to 2.5	0.04	2.7	(1.5)	DIP, SO	C, E
MAX6003	3	3.2 to 12.6	100	1	45µA	75	SOT23	E

MAX6030	3	3.2 to 12.6	20 to 30	0.2 to 0.4	35µA	75	SOT23	E
MAX6193	3	3.2 to 12.6	5 to 25	0.07 to 0.33	35µA	75	SO	E
MAX874	4.096	4.3 to 20	40	0.2	10µA	(60)	DIP, SO	C, E
MAX6004	4.096	4.3 to 12.6	100	1	45µA	100	SOT23	E
MAX6041	4.096	4.3 to 12.6	20 to 30	0.2 to 0.4	35µA	100	SOT23	E
MAX6141	4.096	4.3 to 12.6	50	1	105µA	(25)	SOT23, SO	E
MAX6198	4.096	4.3 to 12.6	5 to 25	0.05 to 0.24	35µA	100	SO	E
MAX6241	4.096	8 to 36	2 to 5	0.025 to 0.1	2.9	(2.4)	DIP, SO	C, E
MAX6341	4.096	8 to 36	1 to 2.5	0.025	2.9	(1.5)	DIP, SO	C, E
MAX6045	4.5	4.7 to 12.6	20 to 30	0.2 to 0.4	35µA	110	SOT23	E
MAX6145	4.5	4.7 to 12.6	50	1	105µA	(30)	SOT23, SO	E
MAX6194	4.5	4.7 to 12.6	5 to 25	0.04 to 0.22	35µA	110	SO	E
MAX675	5	8 to 33	12 to 20	0.15	1.4	15	TO-99, DIP, SO	C, E
MAX875	5	7 to 18	7 to 20	0.06 to 0.1	0.28	(32)	DIP, SO	C, E
MAX6005	5	5.2 to 12.6	100	1	45µA	120	SOT23	E
MAX6050	5	5.2 to 12.6	20 to 30	0.2 to 0.4	35µA	120	SOT23	E
MAX6150	5	5.2 to 12.6	50	1	110µA	(35)	SOT23, SO	E
MAX6195	5	5.2 to 12.6	5 to 25	0.04 to 0.2	35µA	120	SO	E
MAX6250	5	8 to 36	2 to 5	0.02 to 0.1	3	(3)	DIP, SO	C, E
MAX6350	5	8 to 36	1 to 2.5	0.02	3	(1.5)	DIP, SO	C, E
REF02	5	8 to 33	8.5 to 250	0.3 to 2	1.4	15	TO-99, DIP, SO	C

\* Temperature Ranges: C = 0° C to +70° C, E = -40° C to 85° C

## References

1) The Art of Electronics, by Paul Horowitz & Winfield Hill, Chapter 6

## 2) Micro-Electronic Circuits, by Adel S. Sedra & Kenneth C. Smith

### More Information

MAX6001: [QuickView](#) -- [Full \(PDF\) Data Sheet](#) -- [Free Samples](#)  
MAX6002: [QuickView](#) -- [Full \(PDF\) Data Sheet](#) -- [Free Samples](#)  
MAX6003: [QuickView](#) -- [Full \(PDF\) Data Sheet](#) -- [Free Samples](#)  
MAX6004: [QuickView](#) -- [Full \(PDF\) Data Sheet](#) -- [Free Samples](#)  
MAX6005: [QuickView](#) -- [Full \(PDF\) Data Sheet](#) -- [Free Samples](#)  
MAX6012: [QuickView](#) -- [Full \(PDF\) Data Sheet](#) -- [Free Samples](#)  
MAX6021: [QuickView](#) -- [Full \(PDF\) Data Sheet](#) -- [Free Samples](#)  
MAX6025: [QuickView](#) -- [Full \(PDF\) Data Sheet](#) -- [Free Samples](#)  
MAX6030: [QuickView](#) -- [Full \(PDF\) Data Sheet](#) -- [Free Samples](#)  
MAX6041: [QuickView](#) -- [Full \(PDF\) Data Sheet](#) -- [Free Samples](#)  
MAX6045: [QuickView](#) -- [Full \(PDF\) Data Sheet](#) -- [Free Samples](#)  
MAX6050: [QuickView](#) -- [Full \(PDF\) Data Sheet](#) -- [Free Samples](#)  
MAX6120: [QuickView](#) -- [Full \(PDF\) Data Sheet](#) -- [Free Samples](#)  
MAX6125: [QuickView](#) -- [Full \(PDF\) Data Sheet](#) -- [Free Samples](#)  
MAX6141: [QuickView](#) -- [Full \(PDF\) Data Sheet](#) -- [Free Samples](#)  
MAX6145: [QuickView](#) -- [Full \(PDF\) Data Sheet](#) -- [Free Samples](#)  
MAX6150: [QuickView](#) -- [Full \(PDF\) Data Sheet](#) -- [Free Samples](#)  
MAX6160: [QuickView](#) -- [Full \(PDF\) Data Sheet](#) -- [Free Samples](#)  
MAX6190: [QuickView](#) -- [Full \(PDF\) Data Sheet](#) -- [Free Samples](#)  
MAX6191: [QuickView](#) -- [Full \(PDF\) Data Sheet](#) -- [Free Samples](#)  
MAX6192: [QuickView](#) -- [Full \(PDF\) Data Sheet](#) -- [Free Samples](#)  
MAX6193: [QuickView](#) -- [Full \(PDF\) Data Sheet](#) -- [Free Samples](#)  
MAX6194: [QuickView](#) -- [Full \(PDF\) Data Sheet](#) -- [Free Samples](#)  
MAX6195: [QuickView](#) -- [Full \(PDF\) Data Sheet](#) -- [Free Samples](#)  
MAX6198: [QuickView](#) -- [Full \(PDF\) Data Sheet](#) -- [Free Samples](#)  
MAX6225: [QuickView](#) -- [Full \(PDF\) Data Sheet](#) -- [Free Samples](#)  
MAX6241: [QuickView](#) -- [Full \(PDF\) Data Sheet](#) -- [Free Samples](#)  
MAX6250: [QuickView](#) -- [Full \(PDF\) Data Sheet](#) -- [Free Samples](#)  
MAX6325: [QuickView](#) -- [Full \(PDF\) Data Sheet](#) -- [Free Samples](#)  
MAX6341: [QuickView](#) -- [Full \(PDF\) Data Sheet](#) -- [Free Samples](#)  
MAX6350: [QuickView](#) -- [Full \(PDF\) Data Sheet](#) -- [Free Samples](#)  
MAX6520: [QuickView](#) -- [Full \(PDF\) Data Sheet](#) -- [Free Samples](#)  
MAX675: [QuickView](#) -- [Full \(PDF\) Data Sheet](#) -- [Free Samples](#)



MAX872: [QuickView](#) -- [Full \(PDF\) Data Sheet](#) -- [Free Samples](#)

MAX873: [QuickView](#) -- [Full \(PDF\) Data Sheet](#) -- [Free Samples](#)

MAX874: [QuickView](#) -- [Full \(PDF\) Data Sheet](#) -- [Free Samples](#)

MAX875: [QuickView](#) -- [Full \(PDF\) Data Sheet](#) -- [Free Samples](#)

REF02: [QuickView](#) -- [Full \(PDF\) Data Sheet](#) -- [Free Samples](#)