

Introduction

Since their introduction, the single-chip 3¹/₂ digit A/D converters have been widely accepted and used in a variety of digital instrumentation applications. As the number of applications for these low-cost circuits increases, so does the number of specific questions about their operation.

The products covered are Intersil's full line of single-chip 3¹/₂ digit A/D converters. They are:

- ICL7106, ICL7116 for Liquid Crystal Displays (LCD)
- ICL7107, ICL7117 for Light Emitting Diode Displays (LED)
- ICL7126 Micropower Version for LCD

A great deal of versatility has been designed into these devices. All have differential inputs for signal and reference. This permits applications where input and reference are not referred to ground; it also allows the ratio of two signals to be digitally displayed. The devices also feature wide operating ranges for power supply voltage and conversion time.

The first part of this application note will address the most commonly asked questions, the second part consists of a troubleshooting guide, the third section shows normal waveforms, and the fourth gives formulae for component values.

Commonly Asked Questions

Power Supply

Q: What is the minimum battery voltage from which the ICL7106 or ICL7126 can operate?

A: If the internal voltage reference of the circuit is used, the ICL7106 and ICL7126 will operate down to approximately 6.5V. When the battery voltage drops below that level the internal voltage reference will degrade, directly affecting converter accuracy.

If an external voltage reference such as the ICL8069 is used, a lower operating voltage can be used. Care must be taken to ensure that the input common-mode voltage range is not exceeded and that the integrator output swing is kept within its linear region. (See appropriate discussion in data sheets for specifics.) If these parameters are kept in check the ICL7106 and ICL7126 will operate accurately with a battery voltage as low as 4V.

Q: How can the ICL7106 be used with fixed system power supplies?

A: The ICL7106 has been designed to be used with a 9V battery. When ±15V supplies are used, they should be converted to ±5V with simple three terminal regulators such as μA7805 and μA7905, or the low power ICL7663 and ICL7664. If only a +5V supply is available, and

ICL7660 voltage converter circuit can be used to generate -5V at 20mA from the +5V supply. See Figures 1 and 2.

Once a proper dual polarity power supply has been set up, the ICL7106 will make A/D conversions from input voltage referred to power supply ground. Figures 3 and 4 show the use of the ICL7106 with internal and external voltage reference. Note the 27kΩ pull up resistor on analog COMMON (pin 32) when using an external reference.

Q: How well regulated must the power supply for the ICL7107 be?

A: The ICL7107, ICL7106, and ICL7126 have power supply rejection ratios of 86dB typically, and a power supply with 50mV load regulation or better is recommended. High frequency signals and spikes on the power supplies can get into the A/D system, and should be bypassed to ground.

Q: How long will an ICL7106 and an ICL7126 operate from a standard 9V battery?

A: A standard carbon-zinc 9V battery will provide 200 continuous hours of operation for the ICL7106 and 8,000 continuous hours for the ICL7126.

Q: How much power supply current is needed to operate the ICL7107?

A: The supply current from the positive power supply varies from 72mA to 200mA depending upon the combination of display segments lighted. The ICL7107 (without display current) requires typically 1.5mA from the positive supply and 300μA from the negative supply.

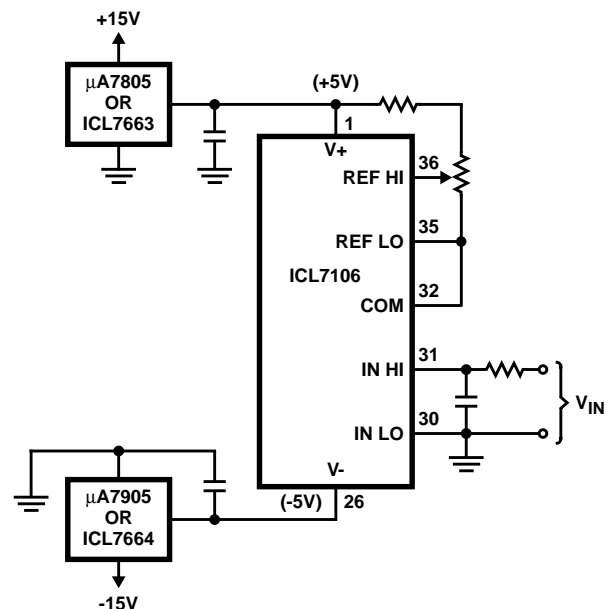

FIGURE 1. OPERATION FROM DUAL POLARITY SUPPLIES WITH INTERNAL VOLTAGE REFERENCE

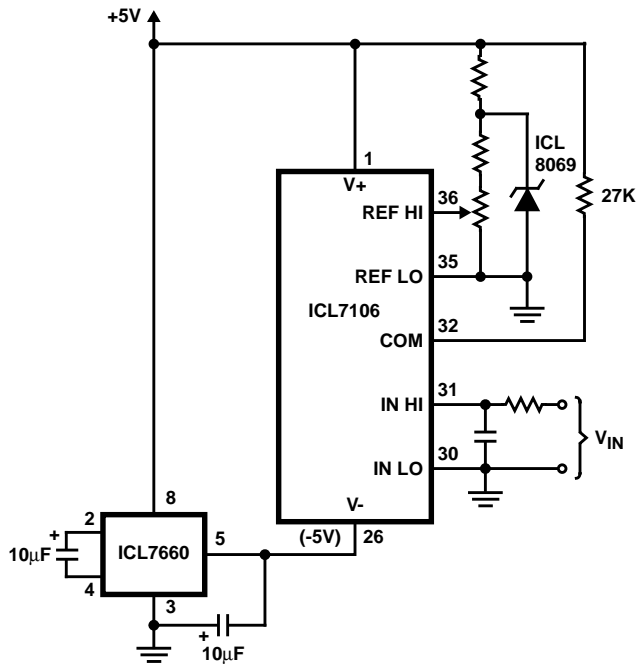

FIGURE 2. OPERATION FROM +5V SUPPLY WITH EXTERNAL VOLTAGE REFERENCE

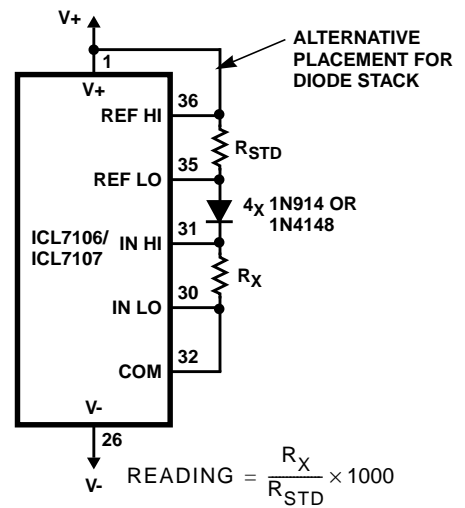
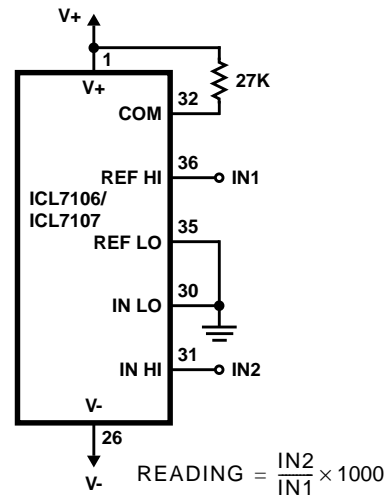

FIGURE 3. EXAMPLES OF RATIOMETRIC OPERATION

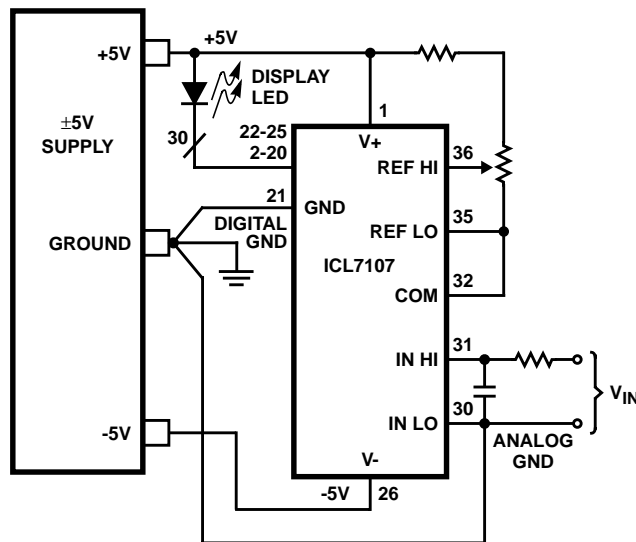

FIGURE 4. GROUNDING DETAIL FOR ICL7107

Q: What is the maximum power supply voltage for the ICL7106 and ICL7107?

A: The ICL7106 has an absolute maximum battery voltage rating of 15V from V+ (pin 1) to V- (pin 26). The ICL7107 has an absolute maximum rating of 6V from V+ to ground (pin 21) and -9V from V- to ground. If the positive voltage to the ICL7107 is greater than 6V, excessive power dissipation will result. To increase LED brightness, use external drivers such as SN7407 or discrete transistors; see ICL7107 data sheet Figure 22.

Display

Q: How can the displayed reading of the ICL7106 or ICL7107 be held for a time rather than continuously updated?

A: The ICL7106 and ICL7107 are designed to continuously update the display as each conversion is completed. For applications where it is desirable to hold the displayed reading, either the ICL7116 (LCD) or the ICL7117 (LED) should be used. These parts are the same as the ICL7106 and ICL7107 except that they have built-in display hold function and slightly different pinout configurations. When the HLD terminal (pin 1) is connected to V+, the displayed reading is frozen and the converter continues in its cycle; when the HLD pin is connected to TEST or Digital Ground (ICL7117 only) the display updates with each conversion. The pinout differences are as follows:

1. Pin 1 is the HLD pin.
2. Pin 35 is the positive power supply pin.
3. REFERENCE LO is internally connected to the analog COMMON point. REFERENCE LO does not connect to a package pin separately.

Q: What types of displays should be used with the ICL7106?

A: The ICL7106 drive signal is approximately 3.5V_{RMS} with a backplane frequency of 60Hz, and will drive almost any size character liquid crystal display. The 0.5in variety is the most common and inexpensive. Suitable displays include the 6FE0203-E and AND, the SX140 from Crystalloid, the 3902-315 from Hamlin, and the 7543-W-2 from LXD.

Q: What types of displays should be used with the ICL7107?

A: Almost any common anode seven-segment LED display will work with the ICL7107. The ICL7107 drives the LEDs with current-limited outputs of 7mA to 8mA per segment; this will automatically compensate the LEDs for different V-I characteristics. For more contrast, use displays that are more efficient. Suitable displays include the Hewlett Packard 5082-7736/30, the ITAC MAN3730/10, the Litronix DL710/7 and the Monsanto 4630/10.

Timing

Q: How fast can the ICL7106 or ICL7107 be operated?

A: The maximum oscillator frequency of the ICL7107 and ICL7106 should normally be considered to be 240kHz. This frequency is the highest frequency that will reject

60Hz noise in the integrator (200kHz for 50Hz rejection). Since the signal integrate phase of the conversion cycle is 1000 clock pulses long, and one cycle of 60Hz lasts $16\frac{2}{3}$ ms, the internal clock frequency is:

$$\frac{1000}{0.01667} = 60\text{kHz}$$

The internal clock is generated by dividing the oscillator frequency by four, therefore, the oscillator frequency will be 240kHz. This corresponds to 15 conversions per second. In applications where 50Hz or 60Hz rejection is not required, the devices may be operated up to 30 readings per second (480kHz). At this high speed, however, the devices may tend to read one count high.

Ratiometric Operation

Q: What is ratiometric operation and how can the ICL7107 or ICL7106 be operated in that manner?

A: In a ratiometric application, the ICL7106 and ICL7107 will display a reading which is proportional to the ratio of two inputs. In this mode, one signal is connected between INPUT HI and INPUT LO, and the other signal is connected between REF HI and REF LO. For signals which share a common connection, INPUT LO and REF LO should be connected. See Figure 3. When the two input signals are equal, the reading will be 1000. The maximum readable ratio of two inputs is 1.999.

Temperature

Q: What variation in reading can be expected with the ICL7106 or ICL7107 when used over the temperature range of 0°C to 70°C?

A: To determine temperature stability of the circuit, analyze each of the three sources of drift.

1. Offset drift is specified to be 1μV/°C maximum. For a 70°C change in temperature, a 70μV change in offset will occur. If the A/D is set for a 200mV full scale, each count corresponds to 100μV. The change in offset for a 70°C change in temperature will be 70/100 or 0.7 counts maximum. In practice, offset drift is likely to be much less than this.

2. Scale factor is specified to be 5ppm/°C maximum. A 70°C change in temperature corresponds to a change in scale factor of 0.035%. The corresponding change in reading will be 0.035% of 2000 counts, or 0.7 counts maximum. In practice, scale factor drift is likely to be much less than this.

3. The temperature coefficient of the internal voltage reference is specified to be 80ppm/°C typically. A 70°C change in temperature will cause a change in reading of 0.56%. The change in reading from this will be 0.56% of 2000 counts or 11.2 counts typically. This is clearly the major source of error in absolute measurements.

Since using the internal reference of the ICL7106 can result in a change in reading of $11.2 + 0.7 + 0.7 = 12.6$ counts over a change in temperature of 70°C, the use of an external reference is recommended.

Using an external reference such as the ICL8069, the change in reading can be kept to 2.8 counts maximum. Such an external reference is recommended for the ICL7107 because of the chip heating caused by power dissipation. This power dissipation is due to the LED drivers, and is not a significant factor when using the ICL7106 over a limited temperature range.

One other effect of increasing temperature on the ICL7106 or ICL7107 is the increase of input leakage currents. This has negligible effect on performance in most applications when recommended component values are used. In more critical applications, increasing the value of C_{REF} and C_{AZ} will minimize these effects.

Components

Q: Can the ICL7126 plug directly into a socket previously occupied by an ICL7106?

A: The ICL7126 and ICL7106 have identical pinout configurations, however, some external component values will have to be recalculated in order to use the ICL7126.

1. The oscillator capacitor (pin 38) should be no more than 50pF, and the oscillator frequency adjusted to 60kHz or less.
2. The current through the reference voltage divider ($V+$ to COMMON pin 32) should be limited to 10 μ A.
3. The integrating capacitor (pin 27) and resistor (pin 28) values should be recalculated. See component selection question or Component Formulae section of this note for further details.
4. The auto-zero capacitor (pin 29) should be 0.33 μ F for 0.2V full scale, or 0.033 μ F for 2V full scale operation.

Q: What types and values of external passive components should be used with the ICL7106, ICL7107, and ICL7126?

A: The oscillator, integrator, and voltage reference divider resistors may be carbon or metal film resistors with a tolerance of 5%, the oscillator capacitor should be a dipped mica or ceramic type with 10% tolerance, and the reference and auto-zero capacitors should be either polystyrene or Mylar™ types with 20% tolerance. The integrating capacitor should be polypropylene, with polystyrene and polycarbonate as second and third choices, respectively. The integrating capacitor must have good dielectric absorption characteristics for the A/D converters to have optimum linearity.

The values for these components depend on the type of converter used. See the Component Formulae section of this application note. These formulas will give an approximate value that is best for a given A/D converter. The actual component value should be the closest standard value that is available.

Troubleshooting Guide

When problems occur with the application of Intersil's family of 3^{1/2} digit A/D converters, they can usually be divided into three categories. These categories are:

1. Accuracy problems.
2. Display problems.
3. Functional problems.

Accuracy Problems

Problem - Above a certain input voltage level, the displayed reading does not linearly track the input.

Action - Observe the waveform at the output of the integrator stage (pin 27) of the A/D converter. There should be no clipping at the positive and negative peaks of the ramped waveform. The value of R_{INT} or C_{INT} may be too small, or the oscillator frequency may be too low, allowing the integrator to saturate. See previous section on component value selection.

Problem - For a constant input voltage, there is a difference in the absolute value of the reading when only the polarity is reversed.

Action - This problem is called "rollover error" and is usually eliminated by proper selection of the integrating capacitor connected to pin 27. A capacitor with good dielectric absorption characteristics is required; polypropylene or polystyrene are the best types of capacitors to use here. Another possible source is that C_{REF} is too small, or that there is excessive stray capacitance to ground from its pins (see AN032).

Problem - For a constant input level, the displayed reading varies as the positive power supply voltage varies.

Action - The connection to analog COMMON (pin 32) should be checked. If the internal voltage reference is used, analog COMMON should **not** be grounded, but rather should be connected to REF LO (pin 35), as shown in Figure 1.

Problem - The displayed reading of the ICL7106 or ICL7107 is not constant for constant input, and changes several counts from one reading to the next.

Action - The connection to analog COMMON should be checked. If external voltage reference is used, the COMMON pin should have a pullup resistor of 27k Ω connected between it and the positive power supply, as shown in Figure 2.

Problem - With the voltage inputs shorted together, there is an offset reading of several counts.

Action - The size of the reference capacitor is too small, or the type of capacitor is too leaky. Use a Mylar™ capacitor of 1 μ F in most applications. Only in applications where input and reference voltage are referred to ground as a common point will a 0.1 μ F capacitor be satisfactory.

Problem - The evaluation kit has been carefully assembled and displays an offset error of several counts when inputs are shorted together.

Action - Proper cleaning of the printed circuit board after assembly should eliminate any leakage paths.

Display Problems

Problem - The displayed reading of the ICL7107 is not stable and changes every conversion cycle.

Action - The connections to power supply ground and signal grounds must be carefully routed to avoid noise problems. Digital ground (pin 21) carries all the LED return current, and should only be connected to INput LO (pin 30) at the power supply terminals. Figure 4 shows how this grounding should be done to keep the LED current from generating a noisy input voltage.

Problem - As power is applied to the ICL7107 with constant input voltage, the reading changes with time and only after a few minutes is stable.

Action - This is caused by the use of the internal reference of the ICL7107 in applications where external LED displays are also being driven. The power dissipated by the LED drivers causes internal chip heating which causes the internal voltage reference to drift. This can be avoided by using an external voltage reference such as the ICL8069, which is considerably more stable than the internal reference of the ICL7107. See Figure 2 for connections.

Problem - The LED display driven by the ICL7107 is not bright enough.

Action - The ICL7107 will typically drive 8mA per segment. This current cannot be varied upward, and will be the same regardless of the size and type of display. To increase brightness, the user should either pick the most efficient display available or use external drivers such as 7407 open collector buffers.

Problem - The LCD display connected to an ICL7106 is weak and occasionally displays incomplete characters.

Action - Low power supply or battery voltage will cause the LCD display to have low contrast. Temperature extremes below 0°C will also cause problems with LCD displays.

Problem - There is permanent distortion or "burning" of the LCD display after prolonged use.

Action - LCD display damage is caused when there is DC drive to a segment or decimal point. Holding the TEST pin (pin 37) high for a long period may also cause display damage.

Functional Problems

Problem - When power is applied to the A/D converter it displays 1666 steadily and does not change.

Action - This is an indication that the oscillator is not functioning. Check oscillator components and printed circuit board for leakage paths around pins 38, 39, and 40.

Problem - The overrange condition (+ or -1 and blank) is continually shown regardless of input voltage.

Action - Check to see if input voltage between pins 30 and 31 is greater than twice the reference voltage. Also check to see that the reference voltage (between pins 35 and 36) or V_{REF} is not shorted out in some way.

Problem - Excess power supply current is drawn after the TEST pin is pulled high and then low.

Action - Make sure that when the TEST pin is dropped it is allowed to float and not returned to the negative power supply level.

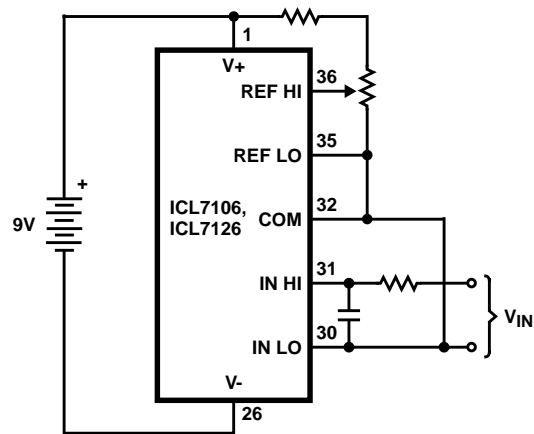

FIGURE 5. OPERATION FROM 9V BATTERY WITH INTERNAL VOLTAGE REFERENCE

Normal Waveforms

Integrator output and buffer amplifier waveforms are shown in Figures 6 and 7 for the two most common configurations of the ICL7106, ICL7107, and ICL7126. Figure 5 shows battery operation with COMMON (pin 32) shorted to INput LO (pin 30). In this case, all voltage measurements are made with respect to COMMON, which is internally set to 2.8V below V_+ terminal (pin 1). During the auto-zero phase of the conversion cycle both INtegrator and BUffEr amplifier outputs are at V_{COM} , the voltage on pin 32. When the integrate portion of the cycle begins, the buffer is switched to the input voltage, V_{IN} , and its output goes to a level equal to $V_{COM} + V_{IN}$. In Figures 6 and 7, the solid line shows the negative input voltage, and the dotted line represents the positive input voltage. During this phase the integrator will ramp in a direction opposite to the input voltage polarity. During the third (de-integrate) phase of the conversion cycle the reference capacitor (pins 33 and 34) is switched between COMMON and the BUffEr amplifier input with the right polarity to make the integrator ramp back to its starting voltage, V_{COM} .

Application Note 052

Dual power supply operation is shown in Figure 1 for the ICL7106 and in Figure 4 for the ICL7107, with INput LO connected to ground in both cases. Figure 7 shows the INtegrator and BUffer amplifier outputs at V_{COM} during the auto-zero part of the conversion cycle, just as in the case of Figures 5 and 6. When the integrate phase starts, the buffer and integrator are switched so that their inputs are referred to ground rather than V_{COM} . The BUffer OUTput goes to a voltage corresponding to V_{IN} , and the integrator begins ramping from ground in a direction opposite to the input voltage polarity. During the third

phase of the cycle, deintegration takes place with respect to V_{COM} and the conversion is complete when the INtegrator output equals V_{COM} .

Figures 8 and 9 show normal clock (OSC 3) and LCD driver waveforms (ICL7106 and ICL7126). Note that in Figures 6 and 7, the buffer and integrator input offset voltages (typically about 20mV) have been neglected. These will move the baselines by the corresponding amount, but will not affect the actual waveforms themselves.

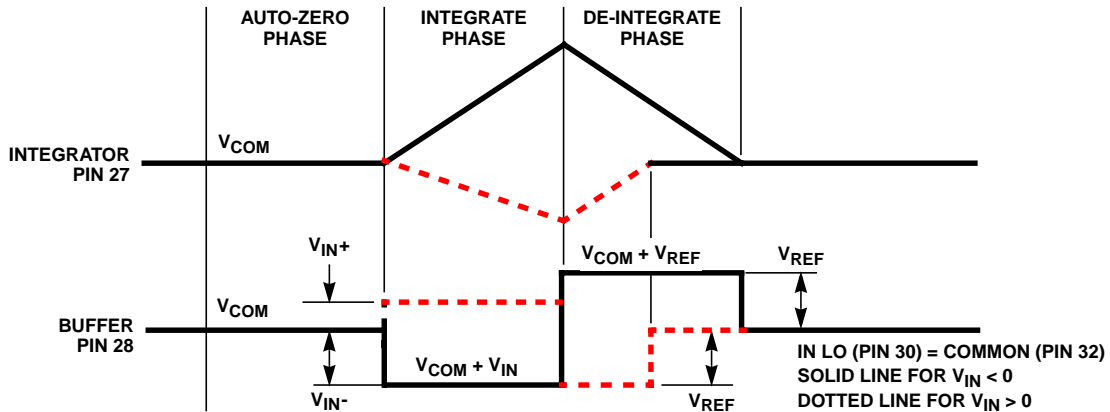

FIGURE 6. INTEGRATOR AND BUFFER WAVEFORMS FOR CIRCUIT OF FIGURE 5

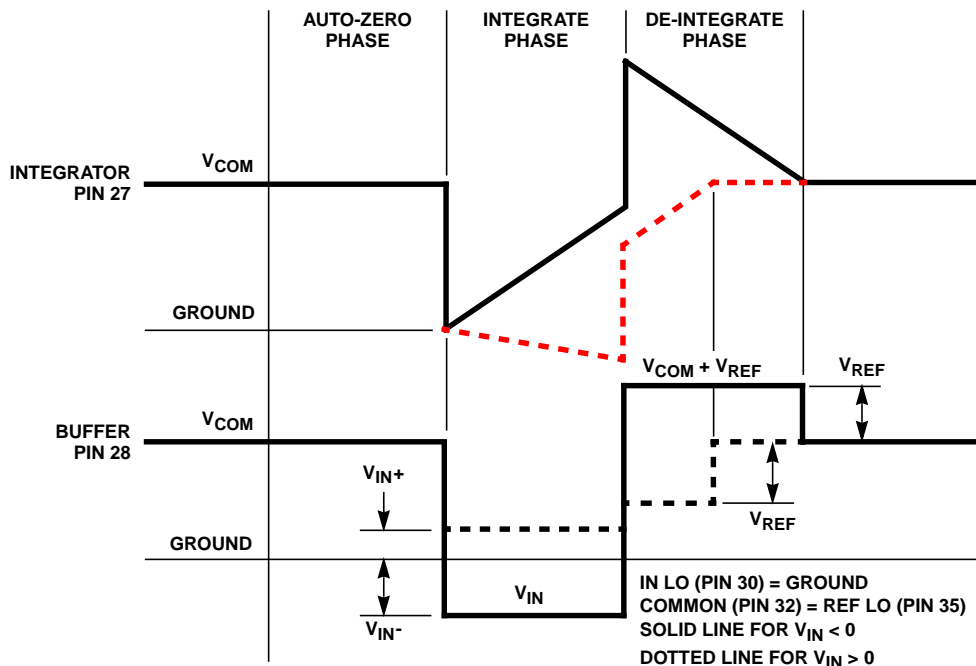

FIGURE 7. INTEGRATOR AND BUFFER WAVEFORMS FOR ICL7106, ICL7126 CONNECTED AS IN FIGURE 1, OR ICL7107 CONNECTED AS IN FIGURE 4

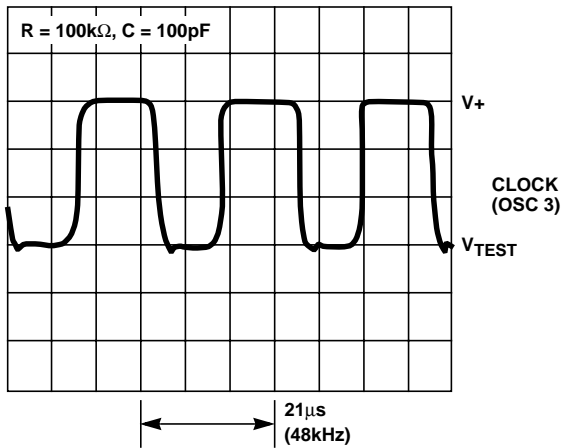

FIGURE 8. CLOCK WAVEFORM ON OSC 3 (PIN 38)

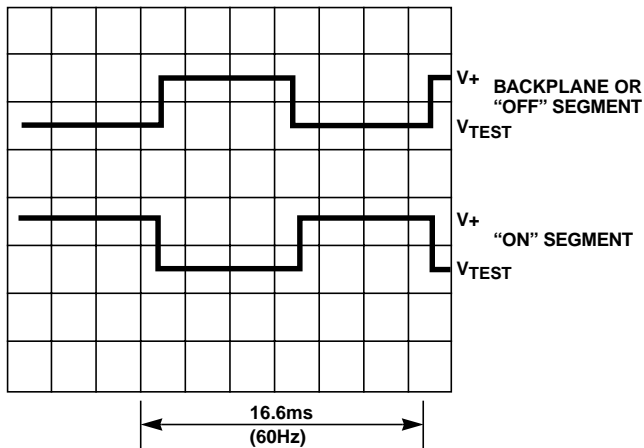

FIGURE 9. LCD DRIVE WAVEFORMS FOR ICL7106 AND ICL7126

Component Formulae

Integrator Resistor and Capacitor (R_{INT} , C_{INT})

$$R_{INT} = \frac{\text{Full scale input voltage}}{I_{INT}}$$

$$C_{INT} = \frac{4000 \times I_{INT}}{\text{Integrator swing} \times f_{OSC}}$$

where I_{INT} is integrator drive current and f_{OSC} is oscillator frequency.

For ICL7106, ICL7107 $I_{INT} = 4\mu\text{A}$

For ICL7126 $I_{INT} = 1\mu\text{A}$

Full scale input voltage is normally that input voltage that will just read (-)1999 or overrange. However, if a more restrictive input (and reading) range is in use, the larger of this maximum input voltage or the reference voltage may be used instead.

Integrator swing for ICL7106 and ICL7126 battery operation is 2V. Integrator swing for $\pm 5\text{V}$ supply operation is 3.5V.

Auto-Zero Cap (C_{AZ})

RANGE	ICL7106, ICL7107	ICL7126
200mV Scale	0.47 μF	0.33 μF
2.0V Scale	0.047 μF	0.033 μF

The value for C_{AZ} should be approximately twice the value for C_{INT} . Increasing C_{AZ} will reduce noise, but slow down recovery from overload or start-up. See Application Note AN032 [5] for more details.

Oscillator Frequency

$$f_{OSC} = \frac{0.45}{R_{OSC} \times C_{OSC}} \text{ (approximately)}$$

where $R_{OSC} > 50\text{k}\Omega$ and $C_{OSC} > 50\text{pF}$ for ICL7106, ICL7107 and where $C_{OSC} \sim 50\text{pF}$ and $f_{OSC} \leq 60\text{kHz}$ for ICL7126.

Note that changing the oscillator frequency may require a change in the value of C_{INT} and C_{AZ} . Also note that the internal clock frequency is equal to one-fourth of the oscillator frequency.

Reference Cap (C_{REF})

Use 1.0 μF for high input to reference common mode voltages or 2.0V full scale input range.

Use 0.1 μF for low input to reference common mode voltages.

Other Products

Much of the discussion given here is also relevant to other A/D converters, such as the ICL7109 and ICL7135, which have an analog section almost identical to that of the ICL7106/ICL7107 etc., and even to chip pairs such as the ICL8052/ICL71C03 and ICL8052/ICL7104.

OSCILLATOR FREQUENCY (kHz)	CONVERSIONS PER SECOND	FREQUENCY REJECTED (Hz)
240	15	60
200	12.5	50
120	7.5	60
100	6.25	50
80	5	60
66.66	4.16	50
60	3.75	60
50	3.12	50
48	3	60
40	2.5	50 and 60
34.28	2.14	60
33.33	2.08	50
30	1.87	60
25	1.56	50
24	1.5	60
20	1.25	50 and 60

Other Application Notes

Some other application notes that may be found useful:

- [1] AN016 *Application Note*, Intersil Corporation, "Selecting A/D Converters", Dave Fullagar, AnswerFAX Doc. No. 9016.
- [2] AN017 *Application Note*, Intersil Corporation, "The Integrating A/D Converter", Lee Evans, AnswerFAX Doc. No. 9017.
- [3] AN018 *Application Note*, Intersil Corporation, "Do's and Don'ts of Applying A/D Converters", Peter Bradshaw and Skip Osgood, AnswerFAX Doc. No. 9018.
- [4] AN023 *Application Note*, Intersil Corporation, "Low Cost Digital Panel Meter Designs and Complete Instruction for LCD and LED Kit", David Fullagar and Michael Dufort, AnswerFAX Doc. No. 9023.
- [5] AN032 *Application Note*, Intersil Corporation "Understanding the Auto-Zero and Common Mode Performance of the ICL7106/7107/7109 Family", Peter Bradshaw, AnswerFAX Doc. No. 9032.
- [6] AN046 *Application Note*, Intersil Corporation, "Building a Battery Operated Auto Ranging DVM with the ICL7106", AnswerFAX Doc. No. 9046.
- [7] AN051 *Application Note*, Intersil Corporation, "Principals and Applications of the ICL7660 Voltage Converter", Peter Bradshaw and Dave Bingham, AnswerFAX Doc. No. 9052.

For Intersil documents available on the internet, see web site <http://www.intersil.com/>
Intersil AnswerFAX (321) 724-7800.

All Intersil semiconductor products are manufactured, assembled and tested under **ISO9000** quality systems certification.

Intersil semiconductor products are sold by description only. Intersil Corporation reserves the right to make changes in circuit design and/or specifications at any time without notice. Accordingly, the reader is cautioned to verify that data sheets are current before placing orders. Information furnished by Intersil is believed to be accurate and reliable. However, no responsibility is assumed by Intersil or its subsidiaries for its use; nor for any infringements of patents or other rights of third parties which may result from its use. No license is granted by implication or otherwise under any patent or patent rights of Intersil or its subsidiaries.

For information regarding Intersil Corporation and its products, see web site <http://www.intersil.com>

Sales Office Headquarters

NORTH AMERICA

Intersil Corporation
P. O. Box 883, Mail Stop 53-204
Melbourne, FL 32902
TEL: (321) 724-7000
FAX: (321) 724-7240

EUROPE

Intersil SA
Mercure Center
100, Rue de la Fusee
1130 Brussels, Belgium
TEL: (32) 2.724.2111
FAX: (32) 2.724.22.05

ASIA

Intersil (Taiwan) Ltd.
7F-6, No. 101 Fu Hsing North Road
Taipei, Taiwan
Republic of China
TEL: (886) 2 2716 9310
FAX: (886) 2 2715 3029