

# Hewlett-Packard Journal Volume 17, Number 9, May 1966, 16 pages

**HEWLETT-PACKARD JOURNAL**  
TECHNICAL INFORMATION FROM THE H. P. LABORATORIES

COMMON MEASUREMENTS MADE WITH A VECTOR VOLTMETER ARE:  
• AMPLITUDE  
• PHASE  
• FREQUENCY  
• MODULATION  
• DISTORTION

### THE RF VECTOR VOLTMETER—AN IMPORTANT NEW INSTRUMENT FOR AMPLITUDE AND PHASE MEASUREMENTS FROM 1 MHz TO 1000 MHz

A broadband, low-loss, high-precision and phase-sensitive instrument for measuring the amplitude and phase of signals from 1 MHz to 1000 MHz. It features a wide frequency range, high accuracy, and low loss.

**FEATURES:**  
• Broadband: 1 MHz to 1000 MHz  
• High Accuracy: ±0.1% (amplitude), ±1° (phase)  
• Low Loss: 0.5 dB (amplitude), 10° (phase)  
• High Impedance: 50 Ω

The block diagram illustrates the internal architecture of the RF Vector Voltmeter, including the input matching network, the main amplifier stage, and the output network.

This graph shows the frequency response of the HP 117A RF Vector Voltmeter, demonstrating its broadband characteristics from 1 MHz to 1000 MHz.

This graph shows the phase response of the HP 117A RF Vector Voltmeter, illustrating the phase shift introduced by the instrument across the frequency range.

This graph shows the modulation response of the HP 117A RF Vector Voltmeter, demonstrating its ability to accurately measure modulated signals.



The page is a technical document with the following layout:

- Top Left:** A large schematic diagram showing a complex circuit with various components and connections.
- Top Center:** A smaller schematic diagram, possibly a sub-circuit or a specific component's internal structure.
- Text Columns:** Multiple columns of text providing technical details, likely describing the circuit's operation, design choices, and performance characteristics.
- Bottom Left:** A smaller schematic diagram, similar in style to the others, showing a different circuit configuration.
- Right Side:** A section containing a table with several rows and columns, likely listing component values, test results, or specifications.

If you have a problem viewing this page or a comment about the scans contact [tyvb](mailto:tyvb).



## HEWLETT-PACKARD JOURNAL

TECHNICAL INFORMATION FROM THE -hp- LABORATORIES

CORPORATE OFFICES • 1501 PAGE MILL ROAD • PALO ALTO, CALIFORNIA 94304 • VOL. 17, NO. 9 MAY 1966

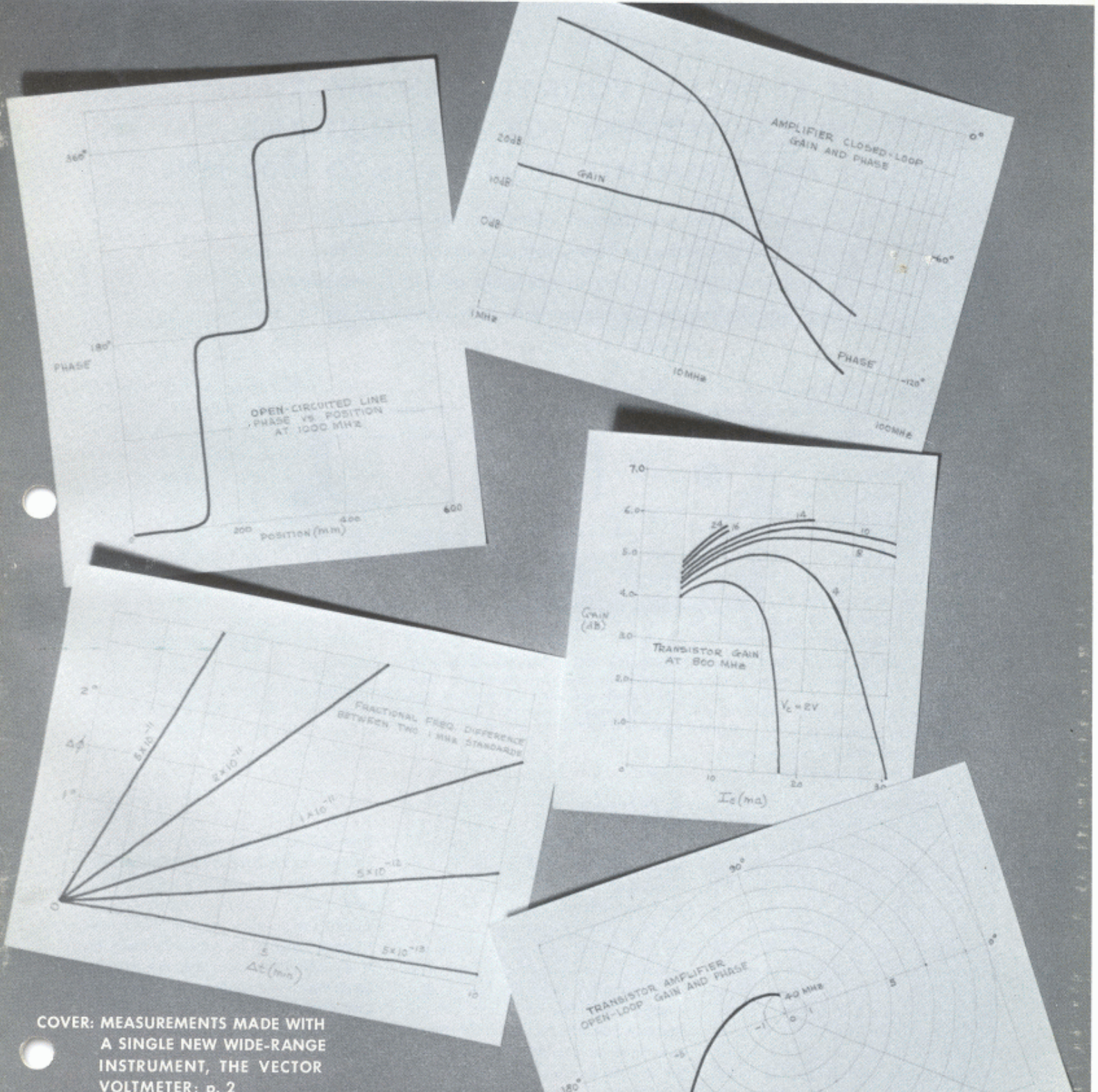

COVER: MEASUREMENTS MADE WITH A SINGLE NEW WIDE-RANGE INSTRUMENT, THE VECTOR VOLTMETER; p. 2

INSTRUMENT, THE VECTOR  
VOLTMETER; p. 2

SEE ALSO: BATTERY-OPERATED  
MULTIMETER; p. 13

PRINTED IN U. S. A.

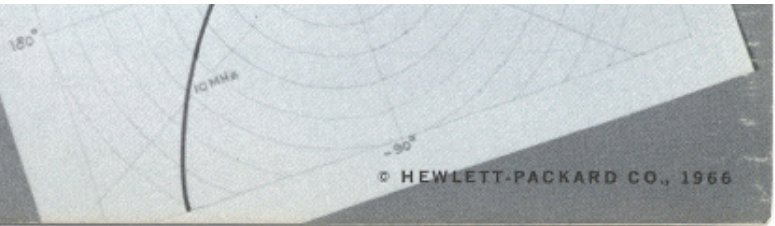

[\(this\) Page 1](#) [\(next\) Page 2](#) [\(last\) Page 16](#)

If you have a problem viewing this page or a comment about the scans contact [tvb](#).

## THE RF VECTOR VOLTMETER—AN IMPORTANT NEW INSTRUMENT FOR AMPLITUDE AND PHASE MEASUREMENTS FROM 1 MHz TO 1000 MHz

A broadband two-channel millivoltmeter and phasemeter simplifies many measurements heretofore often neglected. Included are device gain and loss, impedance and admittance, length inequalities in transmission paths, and precision frequency comparisons.



Fig. 1. —hp— Model 8405A Vector Voltmeter measures amplitudes and phase simultaneously. Instrument has frequency range of 1 MHz to 1 GHz, sensitivity of 100  $\mu$ V full-scale, dynamic range of 95 dB, phase resolution of 0.1°, and is simple to operate. Thus it makes feasible many measurements which formerly were difficult or impossible.

AN IMPORTANT NEW INSTRUMENT, which seems certain to become one of the major electronic measuring instruments, has recently been developed by the —hp— Microwave Division. The RF Vector Voltmeter (Fig. 1) is a two-channel millivoltmeter and phasemeter: it measures the voltage in channel A, and simultaneously measures the phase angle between the fundamental components of the signals in channels A and B; it may then be switched to measure the voltage in channel B so that gain or loss may be determined. It makes these measurements over a broad fre-

of the spectrum where information is often peculiarly difficult to obtain.

Voltage and phase are so fundamental in electrical engineering that the new Vector Voltmeter has an extraordinary number of applications. It can, for example, measure complex or vector parameters such as impedance or admittance, amplifier gain and phase shift, complex insertion loss or gain, complex reflection coefficient, two-port network parameters, and filter transfer functions. It can also be used as a selective receiver and as a design tool: possible applications are detecting RF

istics, detecting Miller effects in tuned RF amplifiers, tuning feedback amplifiers, measuring the electrical length of cables, measuring group delay, and many others.

Although adequate voltmeters for measuring amplitudes over a wide frequency range have been available for some time, there has been no equally convenient means for measuring phase. Consequently, simultaneous measurements of voltage and phase have not always been easy to make. Most systems which are able to measure phase angles require several control adjustments for

or loss may be determined. It makes these measurements over a broad frequency range (1 to 1000 MHz) in a part

lective receiver and as a design tool: possible applications are detecting RF leakage, measuring antenna character-

which are able to measure phase angles require several control adjustments for each measurement, and many of them

• 2 •

---

[\(first\) Page 1](#) **[\(this\) Page 2](#)** [\(next\) Page 3](#) [\(last\) Page 16](#)

---

If you have a problem viewing this page or a comment about the scans contact [tvb](#).

Fig. 2. Block diagram of *-hp-* Model 8405A Vector Voltmeter. Automatic phase control (APC) uses phase-locked loop to tune and phase-lock meter to channel A signal. APC adjusts frequency of voltage-tuned local oscillator (VTO) which triggers sampling-type mixers in probes. RF signals are reconstructed from samples at intermediate frequency of 20 kHz, where voltage and phase are measured.

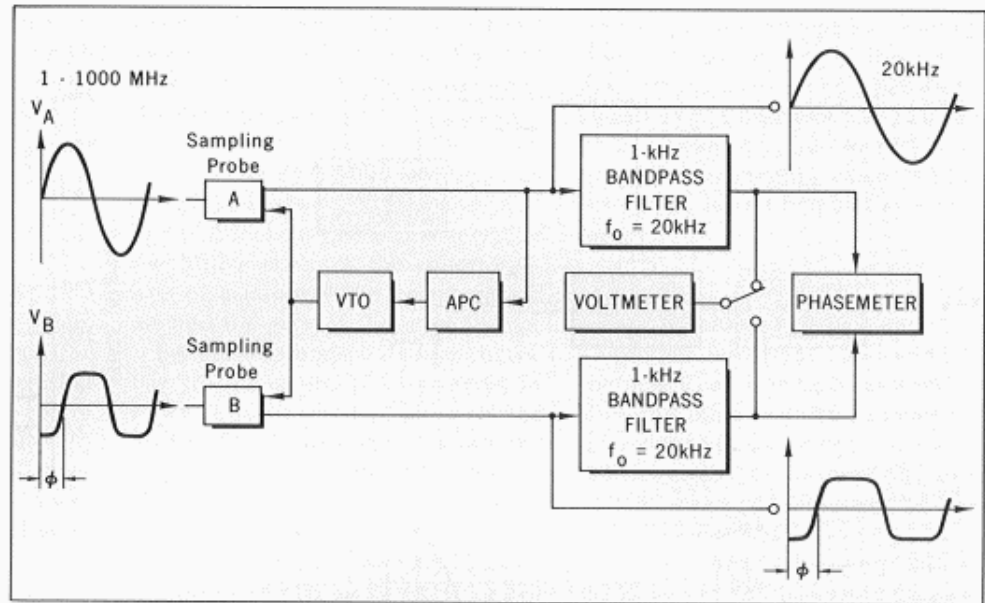

are limited in frequency range, sensitivity, and dynamic range.

The new Vector Voltmeter (VVM), on the other hand, operates over a frequency range of 1 MHz to 1 GHz. It has high sensitivity and wide dynamic range. Its phase resolution is  $0.1^\circ$  at any phase angle at all frequencies, and it operates with the simplicity of a voltmeter: the operator merely selects appropriate meter ranges, touches two probes to the points of interest, and reads voltage and phase on two meters.

As a voltmeter, the VVM has nine voltage ranges, which have full-scale sensitivities of  $100 \mu\text{V}$  to 1 V rms. Its dynamic range is 95 dB, which means that it can measure gains or losses of up to 95 dB. The 10:1 voltage dividers supplied with the instrument enable it to measure voltages up to 10 V.

As a phasemeter, the VVM will measure phase angles between  $+180^\circ$  and  $-180^\circ$ . It has four ranges:  $\pm 180^\circ$ ,  $\pm 60^\circ$ ,  $\pm 18^\circ$ , and  $\pm 6^\circ$ . The phase meter can be offset up to  $\pm 180^\circ$  in  $10^\circ$  steps so that any phase angle may be read on the  $\pm 6^\circ$  range, which has  $0.1^\circ$  resolution. For example, a phase angle of  $+145^\circ$  can be measured with  $0.1^\circ$  resolution by selecting a phasemeter offset of  $+140^\circ$  or  $+150^\circ$  and using the  $\pm 6^\circ$  range. Phase readings are in-

The reference signal for the phase measurement is channel A. An automatic phase control circuit (APC) tunes and phase-locks the instrument to the channel A signal. The frequency range of the APC is selected by means of a front-panel control; there are 21 overlapping ranges, each more than an octave in width. In making a measurement, the operator selects a frequency range which includes the frequency of the signal which is driving the circuit under test. The APC then tunes the instrument automatically and essentially instantaneously (10 milliseconds), and keeps it tuned even if the input frequency drifts or sweeps at moderate rates (up to 15 MHz/second).

In the input probes of the VVM are sampling-type mixers which convert the RF signals to a 20-kHz intermediate frequency, where the voltage and phase measurements are made. Feedback stabilization of the mixers keeps the voltage conversion loss at 0 dB despite environmental influences, and common local-oscillator drive for both samplers keeps the phase difference between the IF signals equal to the phase difference between the RF signals.

The RF waveforms are reconstructed at the intermediate frequency: the fundamental components of the RF

harmonics to 60 kHz, and so on, up to the highest harmonic of the input signal which falls within the 1-GHz bandwidth of the samplers. Outputs are provided directly from the sampling mixers in both channels. Since the input waveforms are preserved in the IF signals, the VVM can be used to convert many low-frequency oscilloscopes, wave analyzers, and distortion analyzers to high-frequency sampling instruments for signals of moderate harmonic content. A similar sampling principle was originally employed by *-hp-* in sampling-type oscilloscopes.<sup>1</sup>

For the voltage and phase measurements, the IF signals from the sampling mixers are filtered so that only their 20-kHz fundamentals remain, and the amplitudes of these fundamentals and the phase angle between them are measured and displayed on the two front-panel meters (see block diagram, Fig. 2). Since only the fundamentals are measured, the amplitude and phase readings are not affected by the harmonic content of the input signals. The narrow-bandwidth IF filters (1 kHz) also reduce thermal noise at the meter inputs. The dc meter signals for both voltage and phase are available at the rear panel and can be used to drive recorders.

the  $\pm 6^\circ$  range. Phase readings are independent of the voltage levels in the two channels.

at the intermediate frequency. The fundamental components of the RF waveforms are converted to 20 kHz, the second harmonics to 40 kHz, the third

to drive recorders.

<sup>1</sup> Roderick Carlson, "The Kilomegacycle Sampling Oscilloscope," *Hewlett-Packard Journal*, Vol. 13, No. 7, March, 1962.

• 3 •

---

[\(first\) Page 1](#) [\(previous\) Page 2](#) **[\(this\) Page 3](#)** [\(next\) Page 4](#) [\(last\) Page 16](#)

---

If you have a problem viewing this page or a comment about the scans contact [tvb](#).

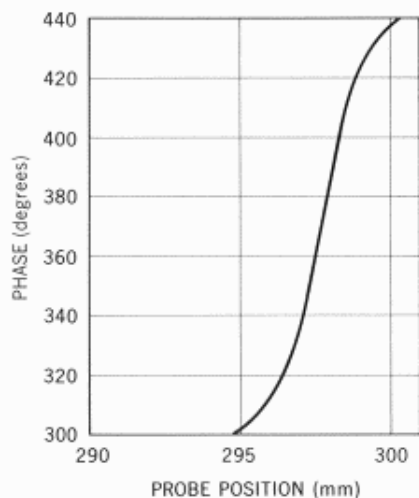
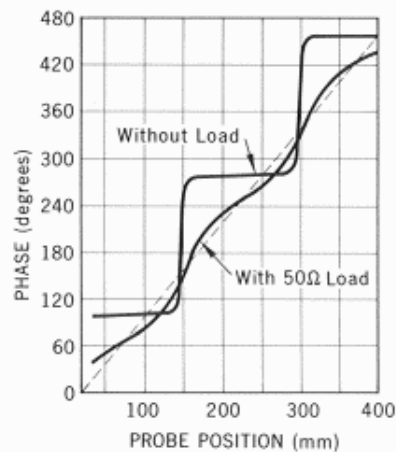
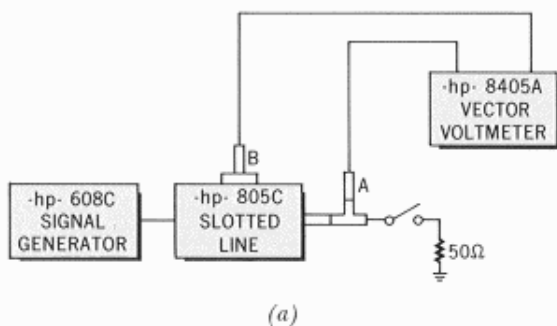

Fig. 3. Demonstration of phase-measuring capabilities of Vector Voltmeter. Phasemeter readings vs. slotted-line probe positions for setup of (a) are plotted in (b). Steepest portion of (b) curves is shown expanded in (c). Maximum rate of change of phase of  $50^\circ/\text{mm}$ , or  $2^\circ$  per human hair diameter, is easily measured. With slotted line terminated in 50 ohms, maximum deviation of phase from linear, theoretically  $22.8^\circ$  for measured VSWR of 2.26, is measured as  $22^\circ$ . Frequency is 1.003 GHz.

**PHASE-MEASURING CAPABILITIES**

Figs. 3(b) and 3(c) demonstrate the phase-measuring capabilities of the Vector Voltmeter. They show, first of all, how the high phase resolution of the VVM makes possible very precise measurements of length. Fig. 3(b) also includes an example of the phase-measurement accuracy of the instrument.

To obtain the data for Figs. 3(b) and 3(c), a 1-GHz signal was applied first to an unloaded slotted line and then to the same slotted line with a 50-ohm load [see block diagram, Fig. 3(a)]. Probe A of the VVM was placed at the output of the slotted line, and probe B was attached to the movable slotted-

phasemeter readings versus the position of the slotted-line probe. The measured curve closely follows the theoretical curve for an open-circuited lossless line.

Without the 50-ohm load, the standing-wave ratio on the line was 50.5. This was determined by measuring the maximum and minimum voltages on the line with the voltmeter of the VVM switched to channel B. The phase-vs-position curve is the step-like curve of Fig. 3(b), and Fig. 3(c) shows one of the steep portions of this curve with an expanded horizontal scale. The maximum rate of change of phase can be determined from Fig. 3(c) to be  $50^\circ$  per millimeter, or  $0.05^\circ$  per micrometer

of a human hair in the position of the slotted-line probe was accompanied by about a  $2^\circ$  phase change, and was easily resolved by the high-resolution ( $0.1^\circ$ ) phasemeter.

With the 50-ohm load, the VSWR was 2.26. Had the VSWR been 1.0, the phase-vs-position curve would have

**CORRECTION**

In the article 'RFI Measurements Down to 10 kHz With Spectrum Analyzer Converter,' Vol. 17, No. 7, March, 1966, the mixer input ports in Fig. 4 are incorrectly labeled. Top port should be labeled 'L,' and center port should be labeled 'X.' It is possible to burn out the mixer if the circuit is not connected properly, or if local oscillator power is too high. Optimum LO power is about 5 mW. Lower power levels can be used, but the third-order intermodulation products of the mixer

output of the slotted line, and probe B was attached to the movable slotted-line probe. Fig. 3(b) is a plot of the

determined from Fig. 3(c) to be  $50^\circ$  per millimeter, or  $0.05^\circ$  per micrometer. Thus, a change equal to the diameter

nign. Optimum LO power is about 5 mW. Lower power levels can be used, but the third-order intermodulation products of the mixer will be larger.

• 4 •

---

[\(first\) Page 1](#) [\(previous\) Page 3](#) **[\(this\) Page 4](#)** [\(next\) Page 5](#) [\(last\) Page 16](#)

---

If you have a problem viewing this page or a comment about the scans contact [tvb](#).

been linear, as shown by the dashed line in Fig. 3(b). The theoretical maximum deviation from linear of the phase curve for a VSWR of 2.26 is

$$\Delta\phi = \arcsin \frac{2.26 - 1}{2.26 + 1} = 22.8^\circ.$$

The measured maximum deviation shown in Fig. 3(b) is about  $22^\circ$ .

#### AMPLIFIER MEASUREMENTS

Fig. 4(b) shows curves of gain, phase, and group delay versus frequency for a transistor amplifier stage operating in the 10-to-12-MHz range. The curves were measured with the Vector Voltmeter in the setup of Fig. 4(a). Compared with previously-available methods, the time and effort required to take the data were minimal.

Two sets of curves are shown in Fig. 4(b). With the switch shown in Fig. 4(a) in the closed position, the gain of

the second amplifier stage was reduced to zero. The solid curves of Fig. 4(b) were obtained with the switch open (second stage gain  $> 1$ ) and the dashed curves were obtained with the switch closed. The difference between the curves shows that the impedance seen by the first stage has been changed by the Miller effect of the collector-to-base capacitance of the second transistor and the gain of the second stage.

Besides amplitude and phase curves, Fig. 4(b) shows group-delay curves, in which delay distortion produced by the Miller effect is apparent. A group delay curve can be obtained either by plotting the slope of the phase curve, or directly from the phasemeter. By changing the input frequency in increments of 2.78 kHz, or 27.8 kHz, or 278 kHz, etc., the group delay can be read directly from the corresponding

changes in the phasemeter readings. The scale factors will in this case be  $1\mu\text{s}$ , 100 ns, or 10 ns, etc., per degree, since  $1\mu\text{s} = 1^\circ$  at 2.78 kHz, and so on. Group delay information is very useful in cable testing, where constant time delay for all frequencies is desirable.

#### MEASUREMENTS OF TRANSISTOR AND NETWORK PARAMETERS

Another important application for the new VVM is measuring transistor gain and other transistor parameters. The wide frequency range of the VVM, and its ability to measure very small signals, make it well-suited for transistor measurements.

Fig. 5(a) shows a test setup which is being used at -hp- to measure transistor scattering parameters, or  $s$ -parameters. The  $s$ -parameters contain the same in-

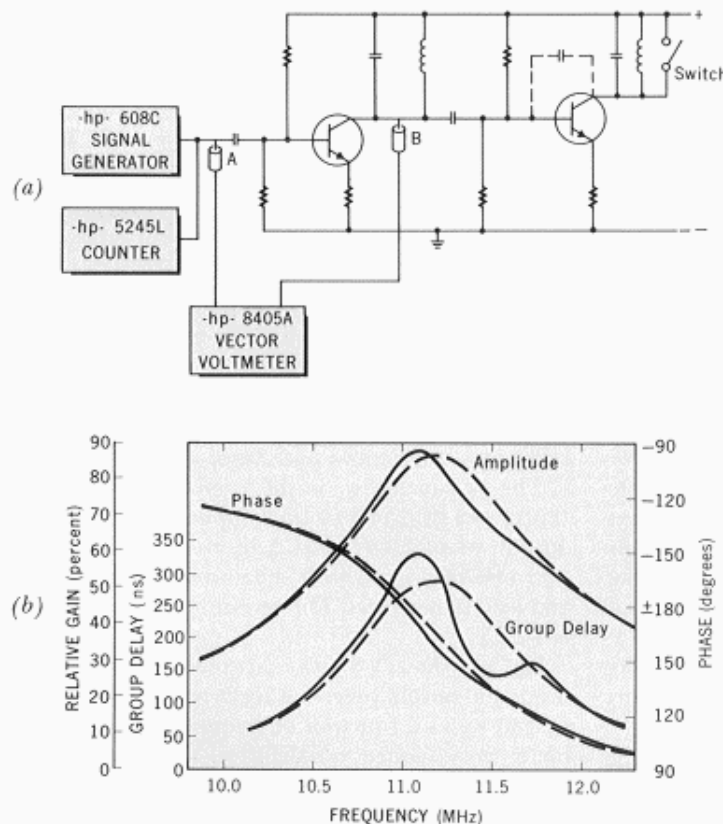

Fig. 4. Typical amplifier gain, phase, and group delay measurements, made with Vector Voltmeter in setup shown in (a). Solid curves of (b) were taken with switch on second amplifier stage open, so that second-stage gain was greater than one. Dashed

curves shows Miller effect of second-stage collector-base capacitance. Group delay curves can be obtained by differentiating phase curve, or by changing input frequency in increments of  $2.78 \times 10^3$  kHz and determining delay from corresponding

second amplifier stage open, so that second-stage gain was greater than one. Dashed curves of (b) were measured with switch closed, second-stage gain = 0. Difference

quency in increments of  $2.78 \times 10^6$  kHz and determining delay from corresponding phasemeter changes with scale factor of  $10^{-n}$   $\mu$ s per degree, where  $n = 0, \pm 1, \pm 2, \dots$

• 5 •

---

[\(first\) Page 1](#) [\(previous\) Page 4](#) **[\(this\) Page 5](#)** [\(next\) Page 6](#) [\(last\) Page 16](#)

---

If you have a problem viewing this page or a comment about the scans contact [tvb](#).

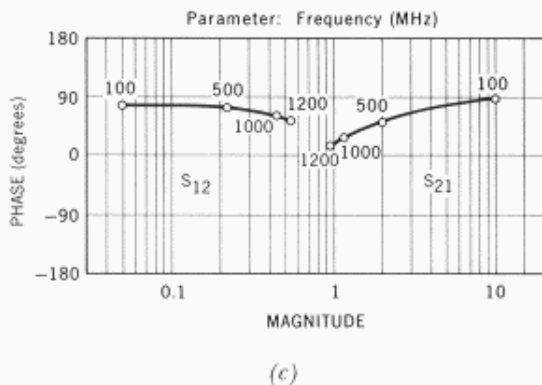
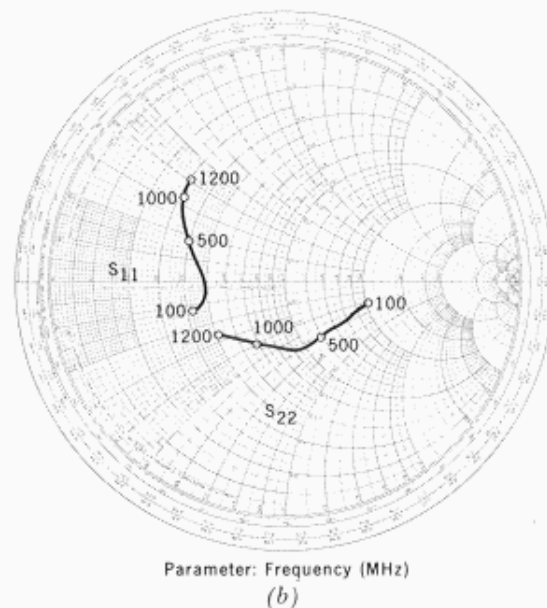
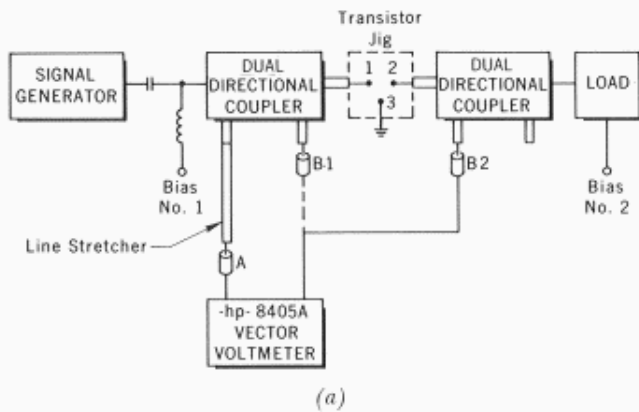

Fig. 5. (a) Setup for measurement of transistor scattering parameters, or  $s$ -parameters. Input reflection coefficient  $s_{11}$  is measured with probe B in position B<sub>1</sub>. Forward gain  $s_{21}$  is measured with probe B in position B<sub>2</sub>. Output reflection coefficient  $s_{22}$  and reverse gain  $s_{12}$  are measured by turning transistor around in special jig and making same measurements as for  $s_{11}$  and  $s_{21}$ , respectively. (b) Amplitude and phase of  $s_{11}$  and  $s_{22}$  measured with Vector Voltmeter are plotted on Smith chart using polar coordinates. Normalized input and output impedances can then be read on impedance scales. (c)  $s_{12}$  and  $s_{21}$  for same transistor. Transistor was in grounded-emitter configuration with 50-ohm source and load impedances.

formation as other common types of two-port network parameters, such as  $y$ -,  $z$ -,  $h$ -, or  $a$ -parameters, but are much easier to measure and to work with at high frequencies because, unlike the other parameters,  $s$ -parameters are not defined in terms of short circuits or open circuits, which are difficult to obtain at high frequencies. Now that transistor gain-bandwidth products greater than 1000 MHz are becoming common, new methods for specifying transistor high-frequency performance are coming into use. The  $s$ -parameters will probably be employed for this pur-

pose more often in the future.<sup>2</sup>

The parameter  $s_{11}$  is the complex reflection coefficient at the input, or port 1, of a two-port network, with the network terminated in equal source and load impedances, usually 50 ohms. The reflection coefficient at port 2 is  $s_{22}$ .

The parameter  $s_{21}$  is the complex transducer gain or loss from input to output, or port 1 to port 2, of a two-port network, again with equal source and load impedances. The reverse gain is  $s_{12}$ .

Fig. 5(b) shows a Smith-chart plot of input and output reflection coefficients  $s_{11}$  and  $s_{22}$  as a function of frequency for a high-frequency transistor. The measurements were made over a wide measurement range from 100 to 1200 MHz with the new Vector Voltmeter, using the setup of Fig. 5(a). The Smith chart is useful for plotting  $s_{11}$  and  $s_{22}$  because the amplitude and phase of these reflection coefficients can be plot-

ted using the polar coordinates of the chart, and then the normalized input reactance and resistance of the network can be read directly from the reactance and resistance scales.

Fig. 5(c) shows plots of reverse and forward gain  $s_{12}$  and  $s_{21}$  obtained with the same transistor as Fig. 5(b), in the circuit of Fig. 5(a).

All of the measurements discussed here, as well as many others, some of which are described briefly on pages 7, 10 and 11 can be made quickly and easily with the new Vector Voltmeter. In the past, these measurements were difficult to make, and often were not made at all, because of the difficulty of obtaining phase information.

### SAMPLING MIXERS

Fig. 7 is a block diagram of the sampling-type harmonic mixers, which are located in the probes. These mixers are similar to those used in  $-hp-$  sampling oscilloscopes. They operate on a strob-

### TIME SIGNAL ADJUSTMENT

Time signals broadcast by NBS Standards Radio Station WWVB (60 kHz) will be retarded 200 milliseconds at 0000 hours, Universal Time, on June 1, 1966, according to an announcement from the National Bureau of Standards. This adjustment is in accordance with the policy of maintaining the WWVB pulses, which conform to the atomic-referenced second, within 100 milliseconds of time

with the policy of maintaining the WWVB pulses, which conform to the atomic-referenced second, within 100 milliseconds of time pulses referred to Universal Time.

these reflection coefficients can be plotted. <sup>2</sup> George E. Bodway, 'Two-Port Power Flow Analysis of Linear Active Circuits Using the Generalized Scattering Parameters'; to be published.

similar to those used in *hp*-sampling oscilloscopes. They operate on a stroboscopic principle, sampling a high-

• 6 •

[\(first\) Page 1](#) [\(previous\) Page 5](#) [\(this\) Page 6](#) [\(next\) Page 7](#) [\(last\) Page 16](#)

If you have a problem viewing this page or a comment about the scans contact [tvb](#).



Fig. 6. Design team for -hp- Model 8405A Vector Voltmeter included (l. to r.) Fritz K. Weinert, final-phase project leader, William R. Hanisch, Allen Baghdasarian, Siegfried H. Linkwitz, Jeffrey L. Thomas, and Roderick Carlson, initial-phase project leader.

frequency periodic input signal at a slightly different phase at each sampling instant and reconstructing a low-frequency image of the signal from the samples. The time between sampling pulses is determined by the frequency of the voltage-tunable local oscillator (VTO), which is controlled by the phase-locked loop.

In operation, the sampler gate is opened for about 300 picoseconds. The input voltage at this time is stored in a 'zero-order hold' circuit until the next sample. The output waveform is a faithful replica of the input, constructed in small steps.<sup>3</sup> Negative feedback is employed to stabilize the voltage conversion loss at 0 dB (output amplitude is same as input amplitude) and to give a high input impedance.

The two probes are ac-coupled and permanently attached to the instrument with 5-foot cables. Loading of the system under test is minimized by the high input impedance of the probes (0.1 megohm shunted by 2.5 pF; with divider, 1 megohm shunted by 2 pF).

**AUTOMATIC PHASE CONTROL**

The phase-locked loop, shown in Fig. 8, tunes the instrument to the signal frequency. The loop is preceded by a high-gain amplifier-limiter which

<sup>3</sup> This process is essentially distortionless; distortion introduced by the sample-and-hold system does not appear in

**THE VECTOR VOLTMETER AS A PRECISION FREQUENCY COMPARATOR**

Adjusting a precision oscillator so that its frequency is the same as that of a standard calls for a precise frequency comparison between two highly stable signal sources. Such frequency comparisons are also needed in studies of aging effects, or long-term stability, in precision oscillators. In these comparisons, frequency differences of a few parts in 10<sup>11</sup> are significant and must be detected.

Most methods for comparing the frequencies of two stable oscillators require long time periods to achieve the required precision. For example, it takes about one day to compare two 5-MHz frequency standards to a precision of one part in 10<sup>11</sup>, by the best of these methods.

By using the Vector Voltmeter to detect the phase difference between the two oscillators, the time required to achieve a precision of one part in 10<sup>11</sup> can be reduced to a few minutes, at typical standard frequencies of 1 MHz or more. The block diagram shows the measurement arrangement.

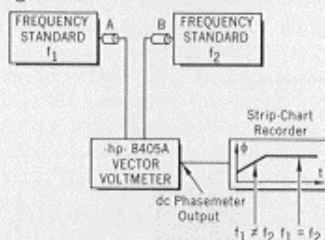

If the frequencies of the two oscillators are the same their phase difference will be constant. If the frequencies differ, the phasemeter reading will change at a rate given by

$$\frac{\Delta\phi}{\Delta t} = 360 \Delta f$$

where  $\Delta\phi$  = phase change in degrees, indicated by VVM

$\Delta t$  = time in seconds required for phase change  $\Delta\phi$

The direction of the phase change tells which frequency is higher; clockwise rotation of the phasemeter pointer indicates that the frequency in channel B is higher than that in channel A.

The phase change and direction of change can be recorded on a strip-chart recorder by connecting the recorder to the dc phasemeter output jack on the rear panel of the VVM. The record shown is a typical recorder trace for two 1-MHz oscillators with a frequency offset of  $2.3 \times 10^{-11}$  Hz, or 2.3 parts in 10<sup>11</sup>. The time



scale is 12 seconds per division, and the full-scale phase difference is 3°. The slope of the trace can be determined within less than one minute, whereas older methods would have required much longer to achieve this precision.

When the Vector Voltmeter is used as a precision frequency comparator, the two oscillators must have low noise, the oscillator frequencies must fall within the range of the VVM (1 MHz to 1 GHz), and the oscillator frequencies must differ by less than a few hertz. Oscillators whose frequencies differ by

<sup>1</sup> This process is essentially distortionless; distortion introduced by the sample-and-hold system does not appear in the IF signals until the 50th harmonic, which is usually much higher than the highest significant harmonic in the input signal.

$\Delta t$  = time in seconds required for phase change  $\Delta\phi$

$\Delta f$  = frequency difference in Hz between input signals.

frequencies must differ by less than a few hertz. Oscillators whose frequencies differ by more than a few hertz should first be tuned coarsely using a counter or an oscilloscope.

• 7 •

---

[\(first\) Page 1](#) [\(previous\) Page 6](#) **[\(this\) Page 7](#)** [\(next\) Page 8](#) [\(last\) Page 16](#)

---

If you have a problem viewing this page or a comment about the scans contact [tvb](#).

Fig. 7. Block diagram of sampling-type harmonic mixers used in new VVM. Mixers operate on stroboscopic principle, sampling RF signal at different points in cycle at successive sampling instants. RF waveforms are reconstructed in small steps at intermediate frequency: fundamental component of RF signal is transposed to 20 kHz, second harmonic to 40 kHz, and so on. Feedback keeps IF voltage equal to RF voltage.

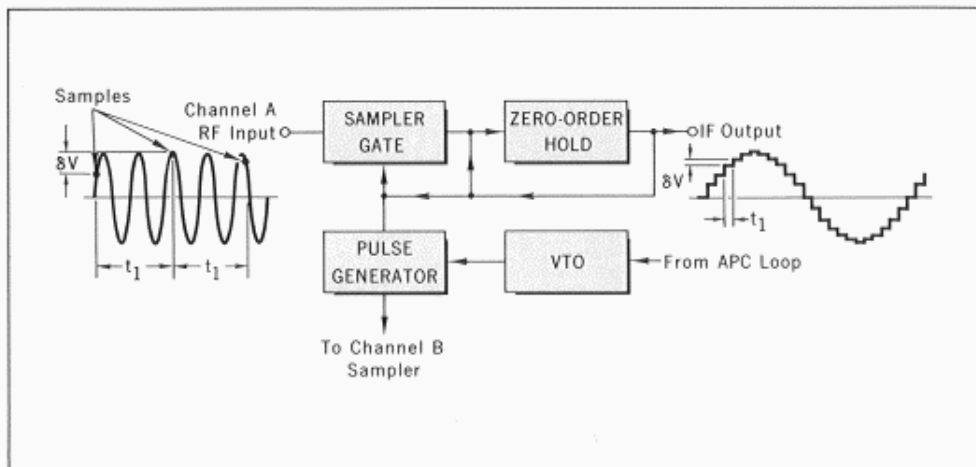

delivers a constant output regardless of the input voltage.

When an RF signal is applied to channel A and the instrument is not tuned properly, the IF is not 20 kHz, and the search generator produces a ramp voltage which adjusts the frequency of the VTO. This changes the time between samples and, consequently, changes the intermediate frequency. When the IF reaches 20 kHz, the loop locks and controls the VTO so as to correct for changes in VTO frequency, signal frequency, or phase modulation.

When the loop is locked, the difference between the signal frequency and

a harmonic of the VTO frequency is exactly the 20-kHz reference oscillator frequency:

$$f_{sig} - nf_{VTO} = \pm 20 \text{ kHz.}$$

The 20-kHz IF can be either the 'inverted' mode or the 'noninverted' mode, depending upon whether the signal is 20 kHz below or 20 kHz above a VTO harmonic. The IF phase difference is identical to the RF phase difference only for the noninverted mode. For the inverted mode, the phase angle is correct, but is lagging when the RF phase angle is leading. A sideband decision circuit detects the sideband mode and starts the search

generator again if the IF mode is inverted. The time required to complete the tuning operation is about 10 milliseconds.

Overall gain of the phase-locked loop is a linear function of the harmonic number to which the signal is locked. A variable attenuator adjusts the loop gain to an optimal value for any signal frequency so that the gain will be sufficient to ensure phase lock but not so high that the loop oscillates. The attenuator control knob is labeled FREQUENCY RANGE, and has 21 overlapping octave-wide bands.

**METER CIRCUITS**

The voltmeter and phasemeter cir-

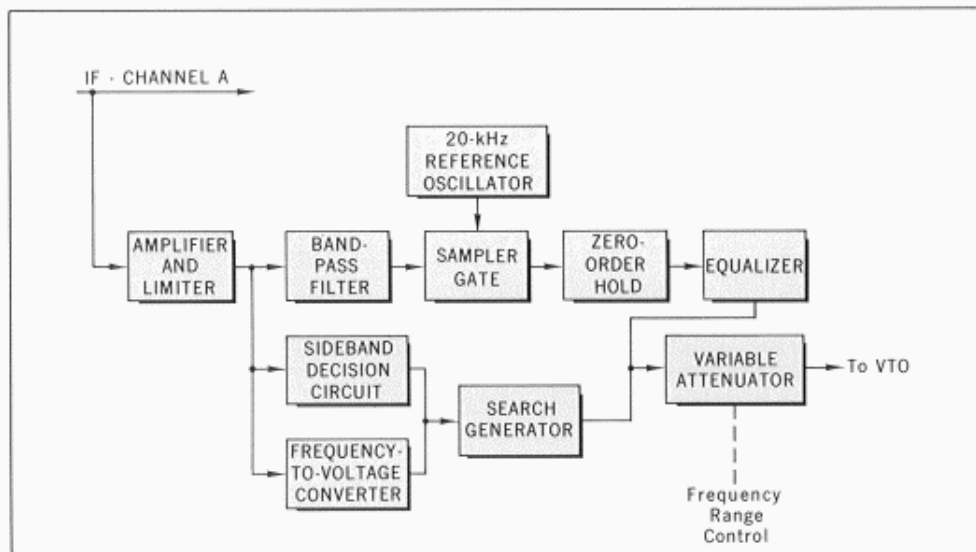

Fig. 8. Block diagram of automatic phase control (APC) circuit, which tunes and phase-locks Vector Voltmeter to channel A signal. APC loop adjusts frequency of voltage-tuned local oscillator (VTO) which generates sampling pulses for mixers, thus keeps IF at 20 kHz. APC requires only 10 ms to tune meter, and remains locked even if input frequency changes at rates up to 15 MHz/s. Sideband decision circuit ensures that  $f_{sig} - nf_{VTO}$  is always +20 kHz, never -20 kHz.

Range  
Control

• 8 •

---

[\(first\) Page 1](#) [\(previous\) Page 7](#) **[\(this\) Page 8](#)** [\(next\) Page 9](#) [\(last\) Page 16](#)

---

If you have a problem viewing this page or a comment about the scans contact [tvb](#).

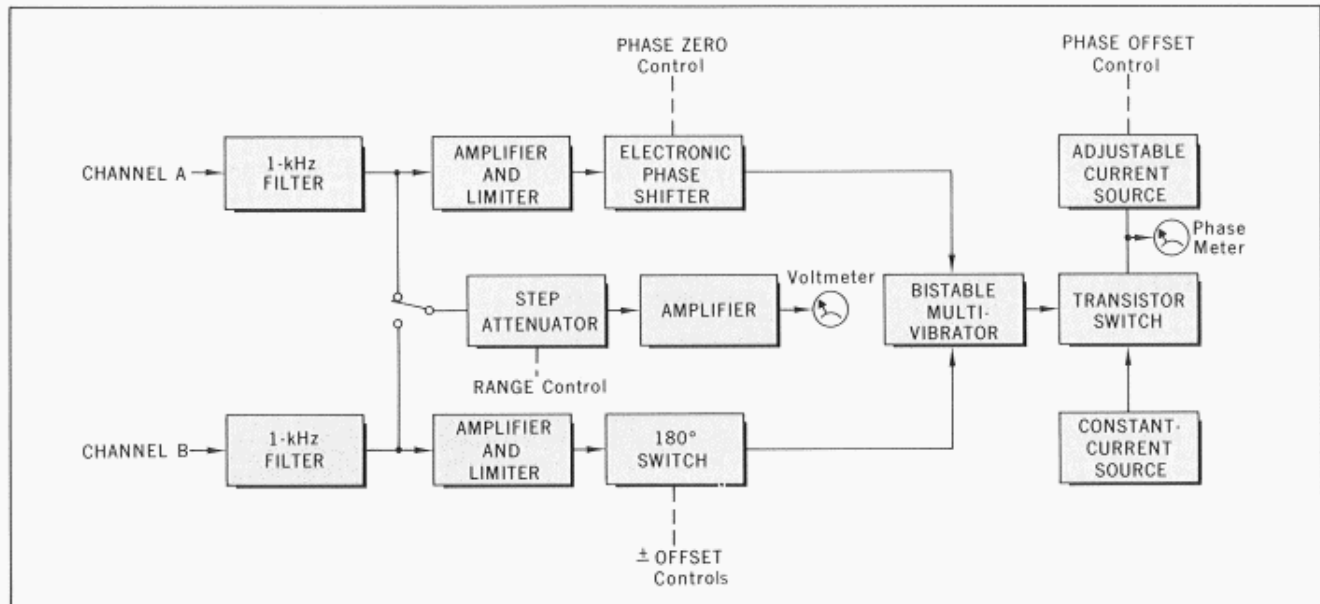

Fig. 9. Block diagram of voltmeter and phasemeter circuits. Amplifier-limiters make phase readings independent of signal levels.

circuits are shown in Fig. 9. The 20-kHz phasemeter has identical amplifiers and limiters in both channels so that the meter reading is independent of the input signal levels.

The phase detector is a bistable multivibrator which is triggered to one of its stable states by channel A and to the other by channel B. The multivibrator operates a transistor switch, which turns the meter current on and off. Another meter input current provides the phase offset, which is adjustable in  $10^\circ$  steps. This kind of phase detector has a very linear characteristic and gives precise phase offset steps in spite of extreme environmental conditions or intermediate-frequency shifts.

#### ACKNOWLEDGMENTS

The Vector Voltmeter design was initiated by a study<sup>1</sup> made by Chu-Sun Yen, Kay B. Magleby, and Gerald J. Alonzo of the -hp- Advanced Research and Development Laboratories. The design group for the Vector Voltmeter has included Roderick Carlson, Allen Baghdasarian, William R. Hanisch, Siegfried H. Linkwitz, Jeffrey L. Thomas, Giacomo J. Vargiu and the undersigned.

— Fritz K. Weinert

#### DESIGN LEADERS



RODERICK CARLSON

Rod Carlson joined -hp- in 1958 as a development engineer. He participated in the design of the -hp- 160A Oscilloscope and was project leader for the development of the -hp- 185A Sampling Oscilloscope. Later he became section manager for sampling oscilloscope development. He transferred to the -hp- Microwave Division in 1964, and was the project leader during the initial development of the -hp- 8405A Vector Voltmeter. He then became manager of the signal analysis section of the Microwave Laboratory, the section concerned with wave and spectrum analyzers, broadband detectors, and power measurement.

Rod holds a BSEE degree from Cornell University. He is a member of IEEE, Tau Beta Pi, Eta Kappa Nu, and Phi Kappa Phi. Before joining -hp-, Rod spent five years as an instrumentation engineer for Cornell Aeronautical Laboratory, dealing with aircraft stability and control under flight conditions.



FRITZ K. WEINERT

Fritz Weinert graduated Magna Cum Laude from Ingenieurschule Gauss, Berlin, Germany, with a degree in electrical communications engineering and precision mechanics. Beginning in 1947, he was associated with several German firms as a development engineer for carrier telephone systems, and as project engineer for a variety of projects dealing with electronic test instruments, antennas, and fields. After coming to the United States in 1960, Fritz spent four years as a project engineer in the development of RFI instrumentation.

Fritz joined -hp- in 1964, becoming project leader for the final development of the 8405A Vector Voltmeter. He is now a project leader in the network analysis section of the -hp- Microwave Laboratory. Fritz holds patents and has published papers dealing with pulse circuits, tapered-line transformers, digital tuned circuits, and shielding systems. He has taught undergraduate electronics and mathematics.

— *Fritz K. Weinert*

\* Chu-Sun Yen, "Phase-Locked Sampling Instruments," IEEE Transactions on Instrumentation and Measurement, Vol. IM-14, Nos. 1 and 2, March-June, 1965.

cal Laboratory, dealing with aircraft stability and control under flight conditions.

digital tuned circuits, and shielding systems. He has taught undergraduate electronics and mathematics.

• 9 •

---

[\(first\) Page 1](#) [\(previous\) Page 8](#) **[\(this\) Page 9](#)** [\(next\) Page 10](#) [\(last\) Page 16](#)

---

If you have a problem viewing this page or a comment about the scans contact [tvb](#).

## SELECTED VECTOR VOLT-

- COMPLEX INSERTION LOSS OR GAIN
- COMPLEX REFLECTION COEFFICIENT
- COMPLEX IMPEDANCE OR ADMITTANCE
- TWO-PORT NETWORK PARAMETERS
- ANTENNA IMPEDANCE AND PHASE CHARACTERISTICS

The arrangement shown in (a) is limited to the frequency range of the directional couplers (usually >200 MHz). The cable or line-stretcher may be needed at the higher frequencies to compensate for phase shift in the directional couplers and other circuitry. A simpler arrangement, useful at lower frequencies, is shown in (b).

Reflection coefficients, input parameters, and impedances are measured with probe B in position B1. Transmission parameters, loss, and gain are measured with probe B in position B2. Input impedance can be determined by plotting magnitude and phase of reflection coefficient on Smith chart and reading normalized impedance on resistance and reactance scales.

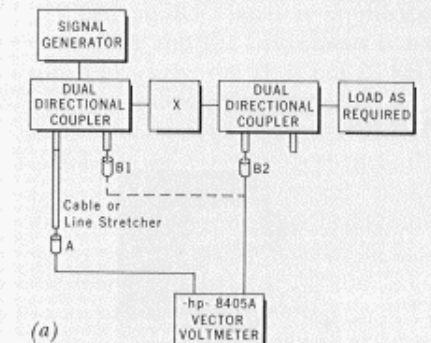

(a)

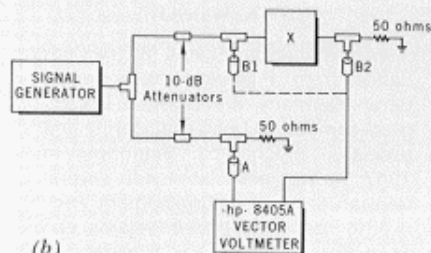

(b)

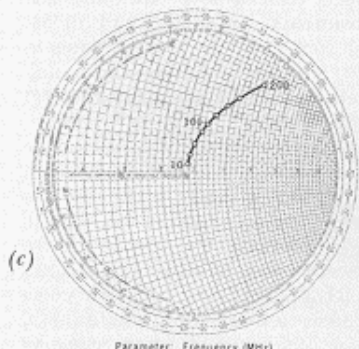

Expanded Smith chart plot of reflection coefficient of 50-ohm ±1% metal film resistor attached to

- GAIN AND PHASE OF ONE OR MORE AMPLIFIER STAGES
- GROUP DELAY AND DISTORTION
- COMPLEX TRANSMISSION COEFFICIENTS
- FILTER TRANSFER FUNCTIONS
- ATTENUATION

Measurements of gain, phase shift, and group delay of any device can be made by placing one probe (A or B) of the Vector Voltmeter at the input of the device and the other probe at the output. The difference between channel A and channel B voltmeter readings in dB is the gain or loss. Phasemeter reading is the phase shift. Group delay is the slope of the phase-vs-frequency curve.

If signal frequency must be measured more accurately than is possible with the signal-generator dial, a counter may be used to measure frequency, or a frequency synthesizer may be used as a signal generator.

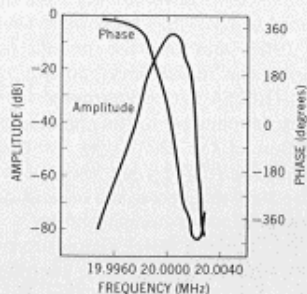
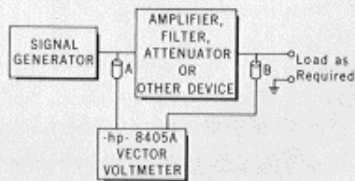

Gain and phase shift of -hp- Model 8442A 20-MHz Crystal Filter as measured with new RF Vec-

- OPEN-LOOP GAIN OF FEEDBACK AMPLIFIERS
- GAIN AND PHASE MARGINS

Closed-loop gain of a feedback amplifier is  $\frac{A}{1-A\beta}$  (a complex number).

$A\beta$  is open-loop gain. If  $-A\beta = -1$ , the feedback is positive and oscillations occur.

Important quantities in feedback amplifier design are gain margin and phase margin, which are measures of the degree of stability of an amplifier. Gain margin is the magnitude of  $-A\beta$ , in dB, at the frequency for which the phase of  $-A\beta$  is  $-180^\circ$ . Phase margin is the difference between  $-180^\circ$  and the phase of  $-A\beta$  at the frequency for which the magnitude of  $-A\beta$  is 0 dB. Typical gain margins are -10 dB to -40 dB, typical phase margins greater than  $30^\circ$ .

The Vector Voltmeter greatly simplifies the design of feedback amplifiers and oscillators by giving both amplitude and phase of open-loop gain simultaneously and quickly.

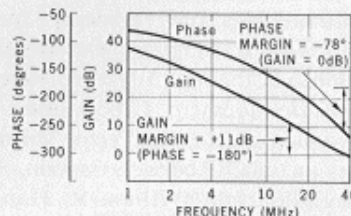
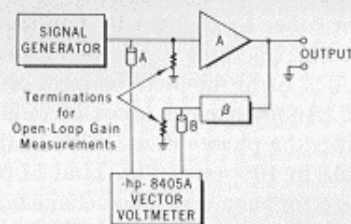

Open-loop gain and phase shift for a transistor amplifier circuit as measured with RF Vector Volt-

Expanded Smith chart plot of reflection coefficient of 50-ohm  $\pm 1\%$  metal film resistor attached to BNC connector. Circuit was (a) with probe B in position B1, resistor as device X, and only one directional coupler.

Gain and phase shift of *-hp-* Model 8442A 20-MHz Crystal Filter as measured with new RF Vector Voltmeter.

Open-loop gain and phase shift for a transistor amplifier circuit as measured with RF Vector Voltmeter. Amplifier was unstable, as gain and phase margins indicate.

## METER MEASUREMENTS

- AMPLITUDE MODULATION INDEX
- RF DISTORTION
- CONVERSION OF LOW-FREQUENCY INSTRUMENTS TO SAMPLING INSTRUMENTS FOR OBSERVATION AND MEASUREMENT OF HIGH-FREQUENCY SIGNALS

Device X is any signal source, 1 MHz to 1 GHz. The Vector Voltmeter converts the fundamental of the RF signal to a 20-kHz IF, the second harmonic to 40 kHz, and so on, so RF waveforms are preserved in the IF signals. The IF output can be used as the input to a low-frequency oscilloscope, distortion analyzer, wave analyzer, or other instrument.

For amplitude-modulated signals, the voltmeter is synchronized to the carrier frequency  $f_c$  and the sidebands  $f_c \pm \Delta f$  are reproduced at the IF as  $20 \text{ kHz} \pm \Delta f$ . Modulation index can be measured using an oscilloscope.

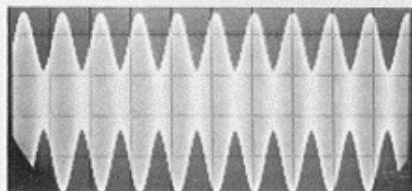
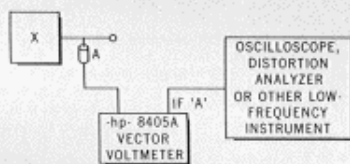

20-kHz IF output of Vector Voltmeter observed on -hp- 120B Oscilloscope (bandwidth = 450 kHz).

- ELECTRICAL LENGTH OF CABLES
- PHASE TRACKING BETWEEN SIGNAL PATHS

The electrical length of a cable can be adjusted precisely using the phase resolution of the Vector Voltmeter. One arrangement for doing this is shown in the block diagram.

To cut a cable to an electrical length of one-quarter wavelength at frequency  $f$ , the signal generator is first tuned precisely to frequency  $f$ . Next, with a short circuit at the output of the directional coupler, the system is calibrated by adjusting the PHASE ZERO control of the VVM until the phasemeter reads  $180^\circ$ . Then the short circuit is replaced by the cable and the cable length is adjusted until the phasemeter again reads  $180^\circ$ . The electrical length of the cable is then one-quarter wavelength.

A cable can be adjusted to the same electrical length as another cable by 1) connecting the first cable to the directional coupler and noting the phasemeter reading, and 2) connecting the second cable and cutting it until the phasemeter reading is the same as for the first cable.

Another method for adjusting two cables to the same length is simply to drive both cables with the same signal source and measure the phase difference between the cable output signals with the VVM. Zero degrees phase difference indicates equal electrical lengths. Phase tracking between any two signal paths can be measured in the same way, that is, by driving both paths with the same source and measuring the phase difference at the path outputs with the VVM.

If the cable or cables must be longer than one-quarter wavelength at the frequencies within the range of the VVM, cable length must first be determined to within one-quarter wavelength by other means (e.g., time domain reflectometry).

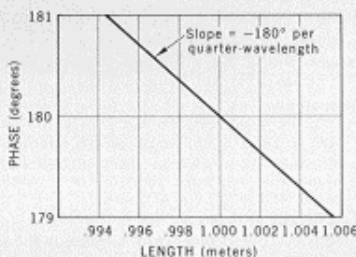
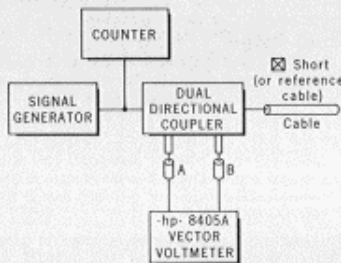

Phase versus length of cable for system shown in block diagram, calibrated at 75 MHz (quarter-

- SELECTIVE RECEIVER
- NEAR-FIELD ANTENNA CHARACTERISTICS
- RF LEAKAGE

The Vector Voltmeter can be used as a selective receiver by synchronizing channel A to the desired frequency or signal, and equipping the channel B probe with an antenna. Meter bandwidth of the VVM is 1 kHz. RF leakage from any device can be detected by this technique. Antenna characteristics can be measured also.

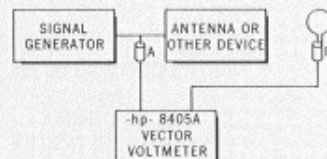

- COMPLEX IMPEDANCE AND ADMITTANCE (AT FREQUENCIES BELOW 100 MHz)

Two simple techniques for measuring impedances at lower frequencies are shown in the accompanying diagrams. These methods are useful if the probe and circuit impedances are negligible in comparison with the unknown and if the reactance of the current transformer or resistor is small.

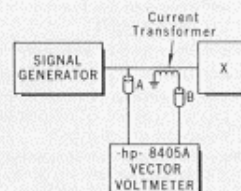
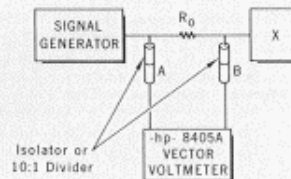

20-kHz IF output of Vector Voltmeter observed on -hp- 120B Oscilloscope (bandwidth = 450 kHz). Input to VVM was 300-MHz carrier, amplitude modulated by 1-kHz signal. Oscilloscope was synchronized to modulating signal only.

Phase versus length of cable for system shown in block diagram, calibrated at 75 MHz (quarter-wavelength = 1 m). Phase resolution of VVM is 0.1°, allowing length to be determined within 0.6 mm at 75 MHz, or more accurately at higher frequencies.

If you have a problem viewing this page or a comment about the scans contact [tvb](#).

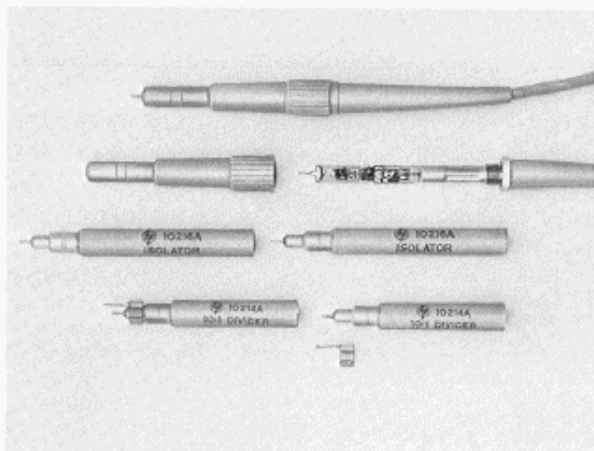

Fig. 10. Probes and accessories for -hp- Model 8405A Vector Voltmeter. Top to bottom: assembled probe; exploded view of probe, showing sampler circuit; isolators, 10:1 dividers, and ground clips supplied with probes. Isolators (or dividers) and ground clips are used when probing by hand in arbitrary circuits. (Tees and adapters are available for probing in 50-ohm coaxial systems.) Dividers extend upper limit of voltmeter range to 10 V. See Specifications for details.

## SPECIFICATIONS

-hp-  
MODEL 8405A  
VECTOR VOLTMETER

**Instrument Type:** Two-channel sampling RF millivoltmeter-phasemeter which measures voltage level in two channels and simultaneously displays the phase angle between the two signals.

**Frequency Range:** 1 MHz to 1 GHz in 21 overlapping octave bands (lowest band covers two octaves).

**Meter Bandwidth:** 1 kHz.

**Tuning:** Automatic within each band. Automatic phase control (APC) circuit responds to the channel A input signal. Search and lock time, approximately 10 millisecond; maximum sweep speed, 15 MHz/sec.

### Voltage Range:

Channel A: 1.5 mV to 1 V rms from 1 to 5 MHz; 300  $\mu$ V to 1 V rms, 5 to 500 MHz; 500  $\mu$ V to 1 V rms, 500 MHz to 1 GHz; can be extended by a factor of 10 with 10214A 10:1 Divider.

Channel B: 100  $\mu$ V to 1 V rms full scale (input to channel A required); can be extended by a factor of 10 with 10214A 10:1 Divider.

**Meter Ranges:** 100  $\mu$ V to 1 V rms full scale in 10 dB steps.

**Full-Scale Voltage Accuracy:** Within  $\pm 2\%$  1 to 100 MHz, within  $\pm 6\%$  to 400 MHz, within  $\pm 12\%$  to 1 GHz, not including response to test-point impedance\*.

**Voltage Response to Test Point Impedance:**  $\pm 0$ ,  $-2\%$  from 25 to 1000 ohms. Effects of test-point impedance are eliminated when 10214A 10:1 Divider or 10216A Isolator is used.

**Residual Noise:** Less than 10  $\mu$ V as indicated on the meter.

**Phase Range:** 360°, indicated on zero-center meter with end-scale ranges of  $\pm 180$ ,  $\pm 60$ ,  $\pm 18$ , and  $\pm 6$ °. Meter indicates phase difference between the fundamental components of the input signals.

**Resolution:** 0.1° at any phase angle.

**Meter Offset:**  $\pm 180$ ° in 10° steps.

**Phase Accuracy:** Within  $\pm 1$ °, not including phase response vs. frequency, amplitude, and test-point impedance.\*

**Phase Response vs. Frequency:** Less than  $\pm 0.2$ ° 1 MHz to 100 MHz, less than  $\pm 3$ ° 100 MHz to 1 GHz.

**Phase Response vs. Signal Amplitude:** Less than  $\pm 2$ ° for an amplitude change from 100  $\mu$ V to 1 V rms.

**Phase Response vs. Test Point Impedance\*:** Less than  $\pm 2$ ° 0 to 50 ohms, less than  $-9$ ° 25 to 1000 ohms. Effects of test-point impedance are eliminated when 10214A 10:1 Divider or 10216A Isolator is used.

**Isolation Between Channels:** Greater than 100 dB 1 to 400 MHz, greater than 75 dB 400 MHz to 1 GHz.

**Input Impedance (nominal):** 0.1 megohm shunted by approximately 2.5 pF; 1 megohm shunted by approximately 2 pF when 10214A 10:1 Divider is used; 0.1 megohm shunted by approximately 5 pF when 10216A Isolator is used, ac coupled.

**Maximum ac Input (for proper operation):** 3 V p-p (30 V p-p when 10214A 10:1 Divider is used).

**Maximum dc Input:**  $\pm 150$  V.

**20 kHz IF Output (each channel):** Reconstructed signals, with 20 kHz fundamental components, having the same amplitude, waveform, and phase relationship as the input signals. Output impedance, 1000 ohms in series with 2000 pF, BNC female connectors.

### Recorder Output:

Amplitude: 0 to +1 Vdc  $\pm 6\%$  open circuit, proportional to voltmeter reading. Output impedance, 1000 ohms; BNC female connector.

Phase: 0 to  $\pm 0.5$  Vdc  $\pm 6\%$ , proportional to phase meter reading; less than 1% effect on Recorder Output and meter reading when external load is  $\geq 10,000$  ohms; BNC female connector.

**RFI:** Conducted and radiated leakage limits are below those specified in MIL-I-6181D and MIL-I-16910C except for pulses emitted from probes. Spectral intensity of these pulses is approximately 60  $\mu$ V/MHz; spectrum extends to approximately 2 GHz. Pulse rate varies from 1 to 2 MHz.

**Power:** 115 or 230 V  $\pm 10\%$ , 50 to 400 Hz, 35 watts.

**Weight:** Net 30 lbs. (13.5 kg). Shipping 35 lbs. (15.8 kg).

### Dimensions:

16 $\frac{3}{4}$  in. wide, 7 $\frac{1}{2}$  in. high, 18 $\frac{1}{2}$  in. deep (425 x 185,2 x 467 mm) overall. Hardware furnished for conversion to rack mount 19 in. wide, 6 $\frac{1}{2}$  in. high, 16 $\frac{1}{2}$  in. deep behind panel (483 x 177,2 x 416 mm).

### Accessories Furnished:

10214A 10:1 Divider (two furnished) for extending voltmeter range. Voltage error introduced is less than  $\pm 6\%$  1 MHz to 700 MHz, less than  $\pm 12\%$  to 1 GHz; if used on one channel only, phase error introduced is less than  $\pm (1 + 0.015f/\text{MHz})$ °. 10216A Isolator (two furnished) for eliminating effect of test-point impedance on sam-

pler\*. Voltage error introduced is less than  $\pm 6\%$  1 to 200 MHz, response is 3 dB down at 500 MHz; if used on one channel only, phase error introduced is less than  $\pm (3 + 0.185f/\text{MHz})$ °.

10213-62102 Ground Clips (six furnished) for 10214A and 10216A.  
5020-0457 Probe Tips (six furnished).

### Accessories Available:

10218A BNC Adapter, converts probe tip to male BNC connector, \$6.00.

10220A Adapter, for connection of Microdot screw-on coaxial connectors to the probe, \$3.50.

10221A 50-ohm Tee, with GR874 RF fittings, for monitoring signals in 50-ohm transmission line without terminating the line, \$40.00.

11529A Accessory Case, for convenient storage of accessories, includes two compartmented shelves and snap-shut lid, \$8.50.

1250-0778 Adapter, both connectors type N male (UG-57B/U).

1250-0780 Adapter, type N male and BNC female (UG-201A/U).

1250-0846 Adapter, Tee, all connectors type N female (UG-28A/U).

General Radio type 874-W50 50-ohm Load (also available from -hp- under part no. 0950-0090).

General Radio type 874-QNP Adapter, GR 874 and type N male (also available from -hp- under part no. 1250-0847).

General Radio type 874-QNJA Adapter, GR 874 and type N female (also available from -hp- under part no. 1250-0240).

General Radio type 874-QBPA Adapter, GR 874 and BNC male (also available from -hp- under part no. 1250-0849).

General Radio type 874-QBJA Adapter, GR 874 and BNC female (also available from -hp- under part no. 1250-0850).

### Complementary Equipment:

774D Dual Directional Coupler, 215 to 450 MHz, \$200.00.

775D Dual Directional Coupler, 450 to 950 MHz, \$200.00.

8491A (Option 10) 10-dB Coaxial Attenuator, \$50.00.

8491A (Option 20) 20-dB Coaxial Attenuator, \$50.00.

**Price:** Model 8405A, \$2500.00.

Prices f.o.b. factory.

Data subject to change without notice.

\* Variations in the high-frequency impedance of test points as the probe is shifted from point to point influence the samplers and can cause the indicated amplitude and phase errors. These errors are different from the effects of any test-point loading due to the input impedance of the probes.

Phase Response vs. Signal Amplitude: Less than  $\pm 2^\circ$  for an amplitude change from 100  $\mu$ V to 1 V rms.

less than  $\pm(1 + 0.015f/\text{MHz})^\circ$ .  
10216A Isolator (two furnished) for eliminating effect of test-point impedance on sam-

These errors are different from the effects of any test-point loading due to the input impedance of the probes.

[\(first\) Page 1](#) [\(previous\) Page 11](#) [\(this\) Page 12](#) [\(next\) Page 13](#) [\(last\) Page 16](#)

If you have a problem viewing this page or a comment about the scans contact [tvb](#).

## A PORTABLE BATTERY-POWERED MULTI-FUNCTION METER WITH LAB-QUALITY PERFORMANCE

A fully-portable laboratory instrument is useful from 1 hertz to 4 megahertz at levels to below 1 millivolt. The instrument is also a sensitive dc voltmeter and ohmmeter.

THE EVER-USEFUL PORTABLE VOLT-OHMMETER finds wide application primarily because it is a passive device requiring no external power. Unencumbered by a line cord, it is easily moved from place to place and it can be readily operated where ac line power is not available. The absence of a line cord has a further advantage in that a common source of ground loops is thereby eliminated.

On the other hand, voltmeters with active components are widely used, even though ac line power may be required, because of the advantages that amplifiers bring to voltmeter performance. Compared to the passive voltmeters, the active types have greater sensitivity, higher input impedance, and, where ac as well as dc voltages are concerned, broader bandwidths.

Nowadays, transistor circuits can be readily included in the design of battery-powered volt-ohmmeters, combin-

ing the advantages of both the active and passive types of instruments with no sacrifice in portability. Accordingly, a new portable transistorized multi-function meter has been designed with performance comparable to laboratory instruments, but it requires only an inexpensive dry-cell battery for power.

The use of active devices makes it possible for this instrument to have high-caliber ac performance. The bandwidth of the new multimeter (-hp- Model 427A) is specified as 10 Hz to 1 MHz but this range represents only the flat portion of the response curve, as shown in Fig. 1. Actually, the instrument is useful throughout a range from 1 Hz to 4 MHz. The most sensitive of the ten ac voltage ranges has been made 10 mV full scale, and the highest range is 300 V full scale. Furthermore, the ac input impedance is 10 megohms on all ranges (shunted by 20 pF or 40 pF, depending on range). Of especial

significance, the meter circuitry is average-responding, which provides readings that approximate true rms values on distorted waveforms more closely than peak-reading voltmeters do.

The dc measuring capabilities also benefit from the use of active devices. DC input impedance is 10 megohms on all dc voltage ranges, in contrast with the usual 20,000 ohms per volt of the passive multimeters, and the most sensitive of the nine dc voltage ranges has been made  $\pm 100$  mV full scale with 1-mV scale resolution (the highest range is 1000 V full scale). Accuracy for both dc and ac voltage measurements is  $\pm 2\%$  of full scale, and this accuracy is maintained throughout a temperature range of  $0^\circ$  to  $50^\circ\text{C}$ . Temperature drift in dc measurements is typically only  $1/2$  mV/ $^\circ\text{C}$  and a front panel control allows any drift on the sensitive dc voltage ranges to be zeroed.

As an ohmmeter, the new multi-

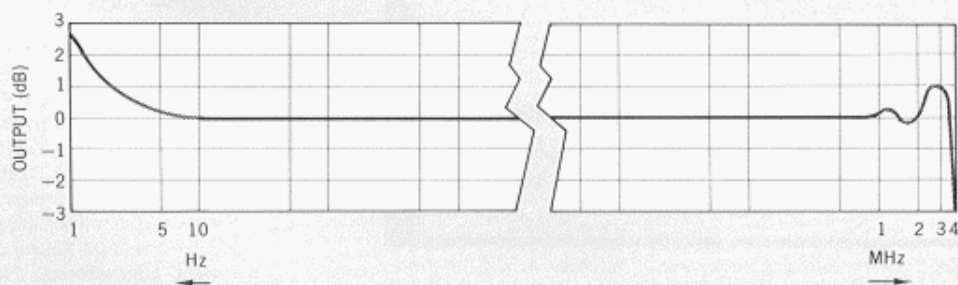

Fig. 1. Frequency response of new -hp- Model 427A Multi-func-

← ————— →  
Fig. 1. Frequency response of new -hp- Model 427A Multi-junction Meter is essentially flat from 10 Hz to 1 MHz but useful response extends to 4 MHz at 3-dB point.

• 13 •

---

[\(first\) Page 1](#) [\(previous\) Page 12](#) **[\(this\) Page 13](#)** [\(next\) Page 14](#) [\(last\) Page 16](#)

---

If you have a problem viewing this page or a comment about the scans contact [tvb](#).

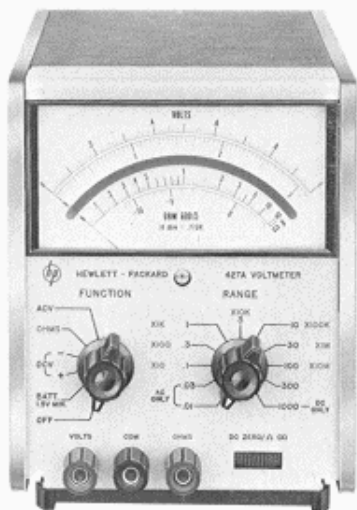

Fig. 2. -hp- Model 427A Voltmeter measures ac volts from 10 mV to 300 volts full scale, resistance in 7 ranges from 10 ohms to 10 megohms center scale, and dc volts from  $\pm 100$  mV to  $\pm 1000$  V full scale. Input impedance is 10 megohms in both ac and dc voltage-measuring modes.

function meter has 7 mid-scale ranges from 10 ohms to 10 megohms with a mid-scale accuracy of  $\pm 5\%$ , and it can read resistance values to as low as 0.2 ohm.

The instrument thus has lab-quality performance, but it retains the ruggedness and portability of the passive multimeter. In addition to being well-suited for all-around use in the lab or service shop, it brings laboratory performance to the field, to boats, to aircraft, or to any situation where ac line power is not readily available.

### COMMON AC AND DC INPUTS

The new multimeter was designed with large rejection of superimposed ac

on dc so that the same floating input terminals can be used for both ac and dc voltage measurements. AC voltages at frequencies of 60 Hz and higher and with peak amplitudes 100 times greater than full scale (up to 450 volts peak) affect a dc reading less than 1%. In the ac mode, the input is capacitively-coupled to remove any dc component from the ac. Thus, both the ac and dc signals at the same point in a circuit, such as dc bias and ac signal level, may be measured without changing input connections.

The separate ohms input is disconnected by internal switching while making voltage measurements to pro-

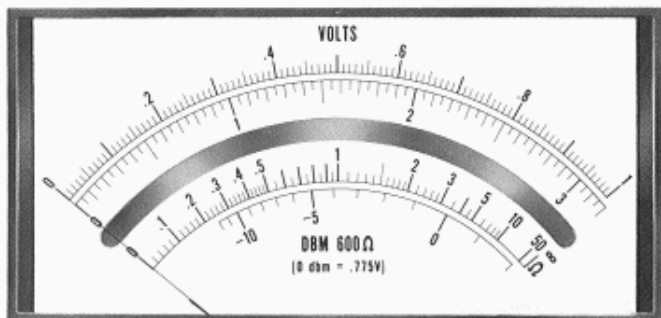

Fig. 3. Each mirror-backed meter scale for new Multi-function Meter is individually calibrated on -hp-'s servo-controlled meter calibrator. Meter face, shown here three-fourths actual size, also includes dB scale calibrated for 600 ohm systems. Meter has

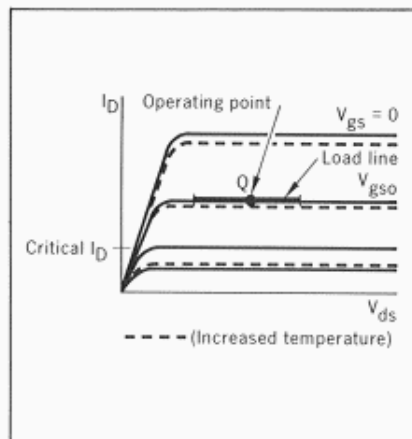

Fig. 4. Typical characteristic curves for field-effect transistor. Increase in temperature changes  $V_{gs}$  of load line to compensate for temperature-induced changes of operating points in associated bi-polar transistors.

### DESIGN LEADERS



James M. Colwell



Noel M. Pace

Jim Colwell joined the -hp- Loveland Division development group after graduation from Purdue University with a BSEE degree in 1964. Since joining -hp-, Jim has worked on amplifiers and metering circuits with the Model 427A Voltmeter as his major responsibility. He is presently studying toward his MSEE degree at Colorado State University. Jim is a member of Eta Kappa Nu and IEEE.

Noel Pace graduated from Stanford University with a BSEE degree in 1956 and did graduate work at the University of California at Berkeley. He began working for Hewlett-Packard in Palo Alto in 1957 as a Development Engineer on the 405A Digital Voltmeter and the 457A AC-to-DC Converter. In 1961, Noel transferred to the Loveland Division where he worked on the 403B Voltmeter, 3550A Test Set, 465A Amplifier, and 651A Test Oscillator. At present, he is a Group Leader in oscillator and amplifier development in the -hp- Loveland Research and Development Laboratories. Noel also spent three years as a communication officer in the U. S. Army Signal Corps.

*Meter is individually calibrated on -hp-s servo-controlled meter calibrator. Meter face, shown here three-fourths actual size, also includes dB scale calibrated for 600-ohm systems. Meter has temperature-compensated, 100- $\mu$ A, taut-band movement.*

three years as a communication officer in the U. S. Army Signal Corps.

• 14 •

---

[\(first\) Page 1](#) [\(previous\) Page 13](#) [\(this\) Page 14](#) [\(next\) Page 15](#) [\(last\) Page 16](#)

---

If you have a problem viewing this page or a comment about the scans contact [tvb](#).



Fig. 5. Typical zero stability of -hp- Model 427A Voltmeter. Record was made in laboratory environment subject to usual temperature fluctuations of  $\pm 2^\circ\text{C}$ .

rect both the instrument and the circuit. All inputs are disconnected when the instrument is turned off, thus removing any loading from external circuits that remain connected to the voltmeter.

#### TEMPERATURE COMPENSATION

A major problem in the design of any sensitive dc measuring instrument concerns drift, which affects reading accuracy. Although chopper amplifiers are widely used to eliminate drift, the design of the -hp- Model 427A Voltmeter did not include a chopper amplifier for two reasons. First of all, the current drain of a chopper system would not permit the use of an inexpensive dry-cell battery. Secondly, the chopper system would increase the cost above the target price level.

In place of a chopper amplifier, an amplifier was designed in which the unavoidable drift of transistors was

counteracted by an equal but opposite drift in the field-effect transistor (FET) input circuit. The FET drain current is supplied from a constant current source, thus placing the load line shown in Fig. 4 parallel to the constant gate-source voltage ( $V_{gs}$ ) lines. The FET is biased above the critical bias point (operating point of zero temperature coefficient) so that the FET operating point (Q) shifts slightly with a change of temperature to compensate for temperature-induced changes in the rest of the amplifier.

Leakage current from the FET gate, which actually amounts to only a fraction of a nanoampere, is opposed in the input attenuator by an equal reverse leakage current from a diode connected in parallel with the FET gate. Minimum offset voltage in the attenuator is thus assured. The reverse-biased diode was selected to have a

temperature coefficient similar to the FET gate.

The measures taken in this instrument to compensate for the temperature susceptibility of solid-state devices, plus the use of metal film resistors, wire-wound potentiometers, and temperature-compensated voltage regulators, result in a total instrument temperature coefficient typically less than  $1/2 \text{ mV}/^\circ\text{C}$ . Operating temperature range is 0 to  $50^\circ\text{C}$ . The overall dc zero stability of the new multimeter under laboratory conditions is shown by the graph of Fig. 5.

#### CIRCUIT ARRANGEMENT

A block diagram of the new multimeter in the dc voltage mode of operation is shown in Fig. 6. The input is fed directly to the precision attenuator and then through the two-section dc filter to the Impedance Converter. The Impedance Converter is a unity-gain

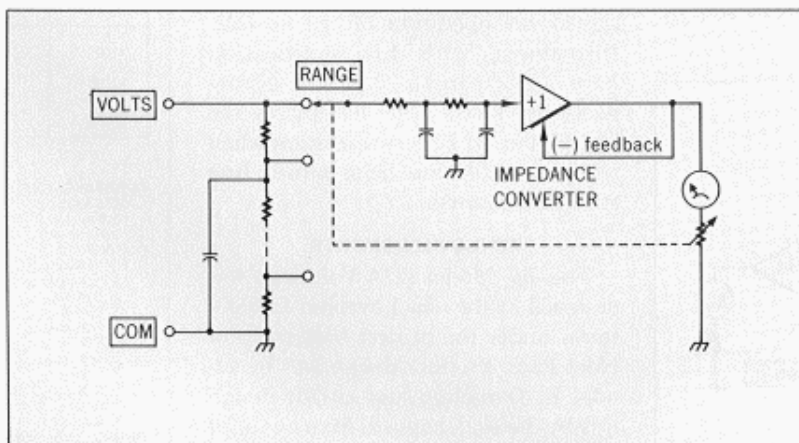

Fig. 6. Block diagram of new multi-function meter in dc voltage

Fig. 6. *Block diagram of new multi-function meter in dc voltage measuring configuration. Range switch at input attenuator also adjusts sensitivity of meter circuit.*

• 15 •

[\(first\) Page 1](#) [\(previous\) Page 14](#) **[\(this\) Page 15](#)** [\(last\) Page 16](#)

If you have a problem viewing this page or a comment about the scans contact [tvb](#).

Fig. 7. AC voltage measuring configuration. Meter rectifier circuit is average-responding.

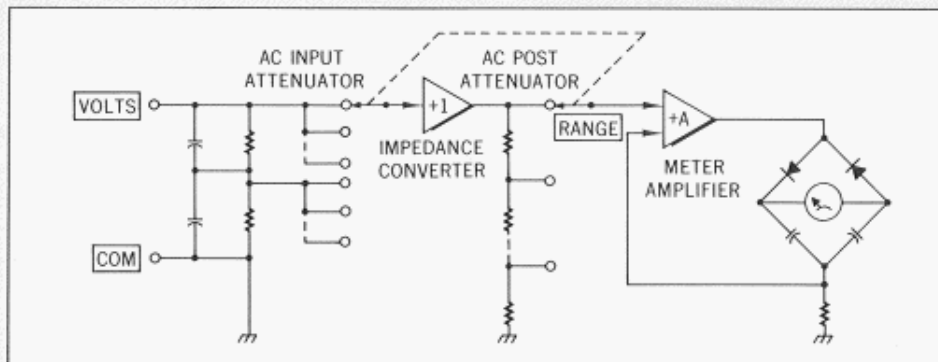

amplifier that matches the input to the low impedance of the meter movement, using the FET to achieve very high input impedance.

The Impedance Converter, which has a response from dc to 4 MHz, is also used in the ac mode of operation to match the high impedance of the input to the low impedance of the broadband ac attenuator (the ac mode also uses a two-step ac attenuator at the input). A second amplifier is switched into the circuit in the ac mode to provide the added gain required for the ac-to-dc conversion (Fig. 7).

The meter rectifiers are arranged in a bridge configuration which permits ac feedback for better linearity and stable gain in the ac mode. Each rectifier conducts for a full half cycle of the ac waveform; hence, the meter responds to the average value of the waveform. The scale, however, is calibrated to read the rms value of a sine wave input.

Resistance measurements use the dc voltage measurement circuits but in-

clude a voltage source to drive current through the unknown resistance, as shown in Fig. 8. The sets of series resistances,  $R_a$  and  $R_b$ , are chosen such that an open circuit at the input causes full scale (infinity) deflection of the meter. When the unknown resistance,  $R_x$ , has the same value as  $R_a$  in parallel with  $R_b$ , meter deflection is half scale.

The ohmmeter infinity adjustment is made by the same front panel control that zeroes the dc voltage ranges.

#### BATTERY POWER

The voltmeter circuits were designed for low current drain, total maximum power dissipation being only 400 mW. One 22.5-V battery thus provides over 300 hours of continuous operation or up to 700 hours of intermittent operation (a series regulator allows the instrument to function with rated accuracy on battery voltages as low as 15 volts).

For those applications where the instrument may remain in one place, a built-in power supply has been designed for operation on an ac line. Instruments with this modification have a rear panel switch that disconnects the power line and places the instrument on battery operation when complete isolation from power line ground is desired.

#### ACKNOWLEDGMENTS

The *-hp-* Model 427A Voltmeter was designed at the *-hp-* Loveland Laboratories under the project leadership of Noel Pace. Product design was by Lionel K. Danielson and circuit design was by the undersigned. Many helpful ideas and suggestions were provided by Marco Negrete.

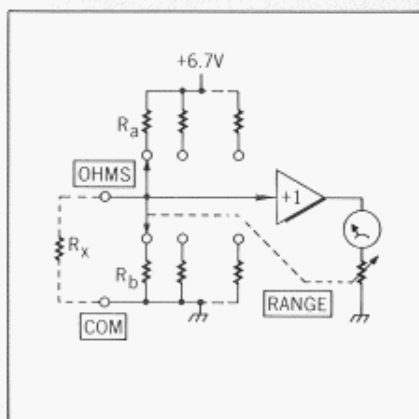

#### SPECIFICATIONS

##### -hp- MODEL 427A VOLTMETER

###### DC VOLTMETER

**VOLTAGE RANGES:**  $\pm 100$  mV to  $\pm 1000$  V full scale in a 1, 3, 10 sequence (9 ranges).  
**ACCURACY:**  $\pm 2\%$  of full scale on any range ( $0^\circ\text{C}$  to  $50^\circ\text{C}$ ).  
**INPUT RESISTANCE:** 10 megohms on all ranges.  
**AC REJECTION:** Superimposed peak AC voltages 60 Hz and above and 100 times greater than full scale affect reading less than 1%. 450 volts peak maximum.  
**OVERLOAD:** 1200 Vdc on any range.

###### AC VOLTMETER

**VOLTAGE RANGES:** 10 mV to 300 V rms full scale in a 1, 3, 10 sequence (10 ranges).  
**FREQUENCY RANGE:** 10 Hz to 1 MHz.  
**ACCURACY:**  $\pm 2\%$  of full scale 10 Hz to 1 MHz,  $.01$  V–30 V (10 Hz to 100 kHz, 100 V–300 V),  $0^\circ\text{C}$  to  $50^\circ\text{C}$ .  
**FREQUENCY RESPONSE:** (See graph, Fig. 1, page 13).  
**INPUT IMPEDANCE:** 10 megohms shunted by 40 pF on 10 mV to 1 V ranges; 20 pF on 3 V to 300 V ranges.  
**RESPONSE:** Responds to average value of input; calibrated in rms volts for sine wave input.  
**OVERLOAD:** 300 V rms momentarily up to 1 V range, 425 V rms maximum above 1 V range.

###### OHMMETER

**RESISTANCE RANGES:** 10 ohms center scale to 10 megohms center scale (7 ranges).  
**ACCURACY:**  $\pm 5\%$  of reading at midscale ( $0^\circ\text{C}$  to  $+50^\circ\text{C}$ ).  
**SOURCE CURRENT:**

RANGE	OPEN CIRCUIT VOLTAGE	SHORT CIRCUIT CURRENT
X10	.1 V	10 mA
X100	.1 V	1 mA
X1 K	1 V	1 mA
X10 K	1 V	100 $\mu\text{A}$
X100 K	1 V	10 $\mu\text{A}$
X1 M	1 V	1 $\mu\text{A}$
X10 M	1 V	0.1 $\mu\text{A}$

###### GENERAL

**FLOATING INPUT:** May be operated up to 500 Vdc above ground. (Ohms input open in any function except 'OHMS'; volts input open when instrument is 'OFF').  
**POWER:** 22½ volt dry cell battery (Eveready No. 763 or RCA VS102).  
**Option 01:** Battery operation and ac line operation (selectable on rear panel). 115 or 230 V  $\pm 20\%$ , 50 Hz to 1000 Hz, ½ W.  
**SIZE:** Standard *-hp-* ½ module. Nominally 5½ in. wide, 6¼ in. high, 8 in. deep.  
**WEIGHT:** Net, 5¼ lbs. (2,36 kg); Shipping, 6½ lbs. (2,9 kg).  
**ACCESSORIES AVAILABLE:**  
 11039A Capacitive voltage divider (1000:1) 25 kV max.  
**PRICE:** *-hp-* 427A: \$195.00 with battery. Option 01: AC line and battery operation \$230.00.

Fig. 8. *Ohmmeter circuits.*

ideas and suggestions were provided by  
Marco Negrete.

— *James M. Colwell*

Option 01: AC line and battery operation  
\$230.00.

Prices f.o.b. factory  
Data subject to change without notice

• 16 •

---

[\(first\) Page 1](#) [\(previous\) Page 15](#) [\(this\) Page 16](#)

---

If you have a problem viewing this page or a comment about the scans contact [tvb](#).